

**HUKX**

Sensor  
Technology

User manual  
Industrial series Class A and  
Class B pyranometers

**SR300-D1**  
**SR200-D1**  
**SR100-D1**

# Cautionary statements

Cautionary statements are subdivided into four categories: danger, warning, caution and notice according to the severity of the risk.

## DANGER

Failure to comply with a danger statement will lead to death or serious physical injuries.

## WARNING

Failure to comply with a warning statement may lead to risk of death or serious physical injuries.

## CAUTION

Failure to comply with a caution statement may lead to risk of minor or moderate physical injuries.

## NOTICE

Failure to comply with a notice may lead to damage to equipment or may compromise reliable operation of the instrument.

# Contents

<b>Cautionary statements</b>	
<b>Contents</b>	<b>2</b>
<b>List of symbols</b>	<b>5</b>
<b>Introduction</b>	<b>6</b>
<b>1 Ordering and checking at delivery</b>	<b>15</b>
1.1 Ordering industrial pyranometers	15
1.2 Included items	15
1.3 Quick instrument check	16
<b>2 Instrument principle and theory</b>	<b>17</b>
2.1 Instrument principle	17
2.2 ISO 9060:2018 pyranometer classification	19
2.3 Spectrally flat pyranometers	19
<b>3 Specifications</b>	<b>21</b>
3.1 General overview	21
3.2 Rated operating conditions	23
3.3 Pyranometer specifications and classification	24
3.4 Electrical specifications	26
3.5 Environmental	31
3.6 Weight and dimensions	31
3.7 Optional accessories	33
3.8 Measurands, certificates and calibration	35
<b>4 Standards and recommended practices for use</b>	<b>40</b>
4.1 Classification standards	40
4.2 General rules for solar radiation measurement	41
4.3 Specific use for PV system performance testing	42
4.4 Specific use in meteorology and climatology	44
4.5 General use for sunshine duration measurement	44
4.6 General use for albedo measurement	44
4.7 General use for diffuse radiation measurement	46
4.8 Reducing environmental impact	46
4.9 Reducing total cost of ownership	46
<b>5 Installation</b>	<b>47</b>
5.1 Site selection	47
5.2 Configuring the instrument	48
5.3 Mechanical installation of the instrument	50
5.4 Electrical installation design	58
5.5 Electrical connections	65
5.6 Setting up Modbus RTU communication	67
5.7 Programming, register structure	68
<b>6 Instrument diagnostics</b>	<b>69</b>
6.1 Instrument diagnostics for different pyranometer models	70
6.2 On-site diagnostics: status LED (SR300-D1 only)	71
6.3 Remote diagnostics	72
<b>7 Maintenance and trouble shooting</b>	<b>80</b>
7.1 Recommended maintenance and quality assurance	80

7.2	Trouble shooting	82
7.3	Calibration and validation	84
7.4	Spare parts	86
7.5	Repair services SR300-D1, SR200-D1 and SR100-D1	86
7.6	The SR300-D1 ventilator	88
7.7	Scratches on domes—optical surface imperfections	88
<b>8</b>	<b>Appendices</b>	<b>91</b>
8.1	Appendix on standards for classification and calibration	91
8.2	Appendix on calibration hierarchy	91
8.3	Appendix on expected change of the WRR scale	93
8.5	Appendix on meteorological radiation quantities	94
8.6	Appendix on ISO 9060:2018 and WMO classification tables	95
8.7	Appendix on ISO 9060:1990 classification no longer valid	97
8.8	Appendix on the definition of pyranometer specifications	99
8.9	Appendix on terminology/glossary	101
8.10	Appendix on uncertainty evaluation	103
8.11	Appendix on accelerometer measurements	106
8.12	Appendix on the Hukx and Hukseflux brand names	107
8.10	EU declaration of conformity	108

# List of symbols

## quantities

relative humidity

## symbol

RH

## unit

%

## subscripts

heater power

$P_{\text{heater}}$

## acronyms

ASTM

American Society for Testing and Materials

GHI

Global Horizontal Irradiance

IEC

International Electrotechnical Commission

ISO

International Organization for Standardization

POA

Plane of Array irradiance

POA<sup>rear</sup>

Rearside Plane of Array irradiance

PV

Photovoltaic

RHI

Reflected Horizontal Irradiance

RPM

Revolutions per Minute

SCADA

Supervisory Control and Data Acquisition

WMO

World Meteorological Organization

GTI

Global Tilted Irradiance

UV

Ultraviolet

EMC

Electromagnetic Compatibility

RVH

Recirculating Ventilation and Heating

WRR

World Radiometric Reference

WSG

World Standard Group

LED

Light Emitting Diode

BSRN

Baseline Surface Radiation Network

LPZ

Lightning Protection Zone

SPD

Surge Protection Device

AWG

American Wire Gauge

MTBF

Mean Time Between Failures

HSAT

Horizontal Single-Axis Tracker

Modbus® is a registered trademark of Schneider Electric, licensed to the Modbus Organization, Inc.

# Introduction

Hukx introduces “industrial-grade” solar radiation monitoring! The all-digital Class A models SR300-D1 and SR200-D1 and Class B model SR100-D1 pyranometers are engineered to measure solar radiation with best-in-class reliability and measurement accuracy.

- ISO 9060 Class A and Class B performance: the right pyranometer for every application and budget
- main applications: PV system performance monitoring and meteorology
- built-in surge protection: engineered to withstand extreme conditions at PV power plants; upgradable to 4 kV with optional SPD01 Surge Protection Device
- flexible integration: RS-485 galvanic isolation guarantees reliable operation and allows flexibility for system designers
- electromagnetic compatibility (EMC): meets IEC 61326-1 Industrial Equipment requirements. Rated for Industrial Electromagnetic Environments
- local safety codes: enables system designers to comply with local safety regulations
- fewer external components: designed to minimize integration costs
- lowest cost of total ownership: supported by a worldwide calibration organization to minimize downtime and reduce operations & maintenance (O&M) costs

Figure 01 Industrial pyranometer models SR300-D1, SR200-D1, and SR100-D1. On the left, the leading Class A model SR300-D1, with heating, tilt sensor, and the blue status LED. In the center and on the right, the non-heated Class A model SR200-D1 and Class B model SR100-D1, respectively



## Industrial, high-accuracy and reliable

SR300-D1, SR200-D1 and SR100-D1 may look like their predecessors, but in many ways, they are entirely new instruments. We built upon the measurement capabilities of the earlier pyranometer models SR30, SR20, and SR15, and tailored the sensors to their most common applications in PV system performance monitoring systems and meteorological stations.

SR300-D1, SR200-D1 and SR100-D1 comply with industrial-grade immunity, emission, electrical, environmental, and safety requirements for use in these outdoor and industrial environments, significantly improving measurement reliability. Ease of operation is further enhanced through advanced functionality and diagnostics.

## SR300-D1 pyranometer for PV power plants

Succeeding our market-leading SR30 model, SR300-D1 is intended for deployment where the highest measurement reliability and accuracy are required. Most importantly, the pyranometer is heated to mitigate dew and frost and has an on-board tilt sensor. See our [SR300-D1](#) product page for more details.

This manual gives general information. There are separate manuals covering communication with a PC, programming and register structure, see below. These can be downloaded via [www.hukx.com/downloads](http://www.hukx.com/downloads)

- Hukx Sensor Manager manual
- Programming manual industrial pyranometers and diffusometers
- a register list for every instrument model

## Pyranometer design

SR300-D1, SR200-D1 and SR100-D1 pyranometers all employ a state-of-the-art thermopile sensor with a black coated surface, two domes and an anodized aluminum body. They offer a digital output via Modbus RTU over 2-wire RS-485.

SR300-D1's dome is heated by actively circulating air between the instrument's inner and outer domes.

## PV system performance monitoring: IEC 61724-1 Class A compliant

There are some differences between SR300-D1, SR200-D1 and SR100-D1. Below you can read more about these differences.

SR300-D1 and SR200-D1 are used for the highest accuracy measurements. SR300-D1 is the best available and recommended instrument for PV system performance monitoring, suitable for all climates. SR200-D1 is used if in the local climate dew and frost are not an issue.

- SR300-D1 and SR200-D1 both comply with IEC requirements for "Class A" PV system performance monitoring. SR300-D1 complies for all locations and climatic conditions, while SR200-D1 is suitable for climates in which dew and frost are not an issue.

- SR300-D1 includes a calibrated tilt sensor complying with IEC 61724-1 requirements for single-axis tracker monitoring and pyranometer tilt measurement accurate within  $\pm 1^\circ$  from -30 to +50 °C.
- SR300-D1 and SR200-D1 include an accredited pyranometer calibration within the required uncertainty limit of IEC 61724-1 for Class A monitoring systems.

SR100-D1 is used to perform basic PV performance and meteorological monitoring at a lower accuracy level than SR300-D1 and SR200-D1.

- SR100-D1 meets the requirements for Class B.
- Suitable for IEC 61724-1 Class B PV system monitoring systems and for Meteorological networks.
- SR100-D1 includes an accredited pyranometer calibration.

Figure 0.2 SR300-D1 includes a digital tilt angle measurement, a practical feature for remote verification of instrument mounting orientation. The above image depicts two SR300-D1 pyranometers, one tilted for Plane of Array (POA) measurement, and another mounted horizontally for Global Horizontal Irradiance (GHI) measurement.



## "Spectrally flat" as required for PV monitoring and meteorology

The ISO 9060 defines pyranometer classes A, B and C. The standard also adds a subclass, called "spectrally flat". All Hukx industrial pyranometers are classified as "spectrally flat". The use of spectrally flat pyranometers is required in PV system performance monitoring (IEC 61724-1) as well as in meteorological monitoring (WMO Guide). See the section on spectrally flat pyranometers for a more detailed explanation.

Surge protection: immunity to high-impulse voltages & currents

SR300-D1, SR200-D1 and SR100-D1 are classified for use in Industrial Environments, according to IEC 61326-1 and IEC 61000-6-2. When designing a measuring system, pyranometer users may reach several levels of immunity.

With the optional Surge Protection Device SPD01, this immunity can be increased to 4 kV. Up to 3 pyranometers can be protected with a single SPD01. A third-party SPD with similar specifications may also be used.

To attain the required level of immunity for a given installation, some general system components should be included, such as:

- lightning protection system
- earthing and grounding network
- external surge protection, in addition to the native on-board protection

## Surge protection: immunity to high-impulse voltages & currents

SR300-D1, SR200-D1 and SR100-D1 are classified for use in Industrial Environments, according to IEC 61326-1 and IEC 61000-6-2. When designing a measuring system, pyranometer users may reach several levels of immunity.

With the optional Surge Protection Device **SPD01**, this immunity can be increased to 4 kV. Up to 3 pyranometers can be protected with a single SPD01. A third-party SPD with similar specifications may also be used.

To attain the required level of immunity for a given installation, some general system components should be included, such as:

- lightning protection system
- earthing and grounding network
- external surge protection, in addition to the native on-board protection



Figure 0.3 The SPD01 Surge Protection Device.

### Improved surge protection and earthing compared to earlier models

The new digital industrial pyranometers SR300-D1, SR200-D1 and SR100-D1 are better protected against surges than the earlier digital pyranometer models SR30-M2-D1, SR20-D2 and SR15-D1. This applies to all installation scenarios, irrespective of the cable length used. Added to that, the connection to earth ground of the new models with their dedicated earthing terminal (also called grounding terminal or ground lug) is much more reliable than that of earlier models. For connection to earth these models relied on bolts that are primarily designed for use as mechanical connection rather than a low-resistance electrical connection.

### RS-485 isolation

The RS-485 interface of the industrial pyranometers is galvanically isolated from its internal electronics, as well as the instrument body. Both isolation barriers are rated at 1.5 kV. This contributes to reliable operation, flexibility in system design, and reduced integration costs for all industrial pyranometers.

### Electrical safety in the workplace

A PV power plant is a potentially hazardous workplace environment. To comply with safety regulations, SR300-D1, SR200-D1 and SR100-D1 feature a dedicated earthing terminal for connection to protective earth. When the pyranometer is isolated from the mounting platform, it can still be properly earthed via this terminal.

SR300-D1, SR200-D1 and SR100-D1 allow system designers to comply with safety regulations. These are often based on EU and US electrical safety standards, such as:

- EN-50110 Operation of Electrical Installations
- NFPA 70 National Electrical Code (NEC)



Figure 0.4 SR300-D1, SR200-D1, SR100-D1 with yellow/green wire connected to its earthing terminal for compliance with EU and US safety regulations.

## Lowest total cost of ownership

Customers prefer Hukx pyranometers for their unsurpassed measurement accuracy and lowest cost of ownership. Total ownership costs are primarily determined by installation, on-site inspection, accidental damage, and calibration.

- fewer external components: Internal protection and isolation reduce the requirements and costs for added external protection devices.
- minimize risk of damage: Preventive measures, such as surge protection and dome protection, lower the risk of accidental damage.
- worldwide calibration organization: Pyranometers must be calibrated every 2 years. Our worldwide calibration organization reduces calibration costs by simplifying return logistics and turnaround times. Learn more about [pyranometer calibration services](#).
- efficient O&M: Minimize inspection with built-in remote sensor diagnostics and quickly install using spring-loaded leveling and (for SR300-D1) on-site status-LED diagnostics.

## SR300-D1: heated for high data availability, operation in 3 power modes

SR300-D1 includes internal heating. Heating mitigates dew and frost, which leads to high data availability. Heating is achieved by actively circulating air between the instrument's inner and outer domes. This space forms a closed circuit together with the instrument body; ventilated air is not in contact with ambient air. RVH™—Recirculating Ventilation and Heating—technology, developed by Hukx, is as effective as traditional ventilation systems while consuming less power and without the maintenance hassle and large footprint.

Heater and ventilation may be remotely switched on and off. The SR300-D1 has three power modes:

- Normal power mode. In this mode, the instrument is heated and ventilated for optimal dew and frost mitigation. Ventilation also reduces zero offsets.
- Medium power mode. In this mode, the instrument is unheated and only ventilated. In situations where dew and frost are not an issue, this leads to the highest measurement accuracy and lowest possible instrument offsets. In some cases, ventilation alone may also be sufficient to prevent dew and frost formation.
- Low power mode. In this mode, the instrument is not heated and not ventilated to minimize power consumption.

The SR300-D1 meets ISO 9060 Class A requirements in all three power modes.

The SR200-D1 and SR100-D1 pyranometers do not employ heating. Therefore, we recommend using SR300-D1 pyranometers for locations with frequent dew and frost occurrences.

Figure 0.5 (left image)  
SR300-D1 is heated to counter frost and dew deposition: clear difference between a non-heated pyranometer (back) and a heated pyranometer (front).

Figure 0.6 (right image)  
SR300-D1 includes a digital tilt angle measurement, very practical for remote checks of instrument orientation. The image shows two SR300-D1's in PV system monitoring, one measuring in Plane of Array (POA).



### SR300-D1: Calibrated tilt angle measurement

SR300-D1 includes an accelerometer. The accelerometer is used for pyranometer tilt angle measurement. Gravitational acceleration in x, y, and z-directions, and tilt in two orthogonal directions can also be read out separately. This is very useful for remote checks of instrument installation and identifying tracker system faults. For PV systems with single-axis trackers, IEC 61724-1 Class A performance monitoring systems also require a tilt angle measurement of the tracker. This is done by mounting SR300-D1 attached to the module frame.

Every SR300-D1 accelerometer is individually calibrated and temperature compensated between -30 and +50 °C, resulting in a high measurement accuracy of  $< \pm 1^\circ$ , meeting the requirement by IEC 61724-1 for class A systems.

## Communication with a PC: Hukx Sensor Manager software

The Hukx Sensor Manager software can be used for communication between a PC and Hukx industrial pyranometers. The latest version of the Hukx Sensor Manager can be downloaded via [www.hukx.com/downloads](http://www.hukx.com/downloads). The Hukx Sensor Manager allows the user to easily configure the pyranometer: set the pyranometer device address and its communication settings. It can also be used to plot and export instrument data and view sensor diagnostics.

See the [Hukx Sensor Manager user manual](#).

Figure 0.7 Main window of the Hukx Sensor Manager. The software allows the user to change the device address and communication settings.

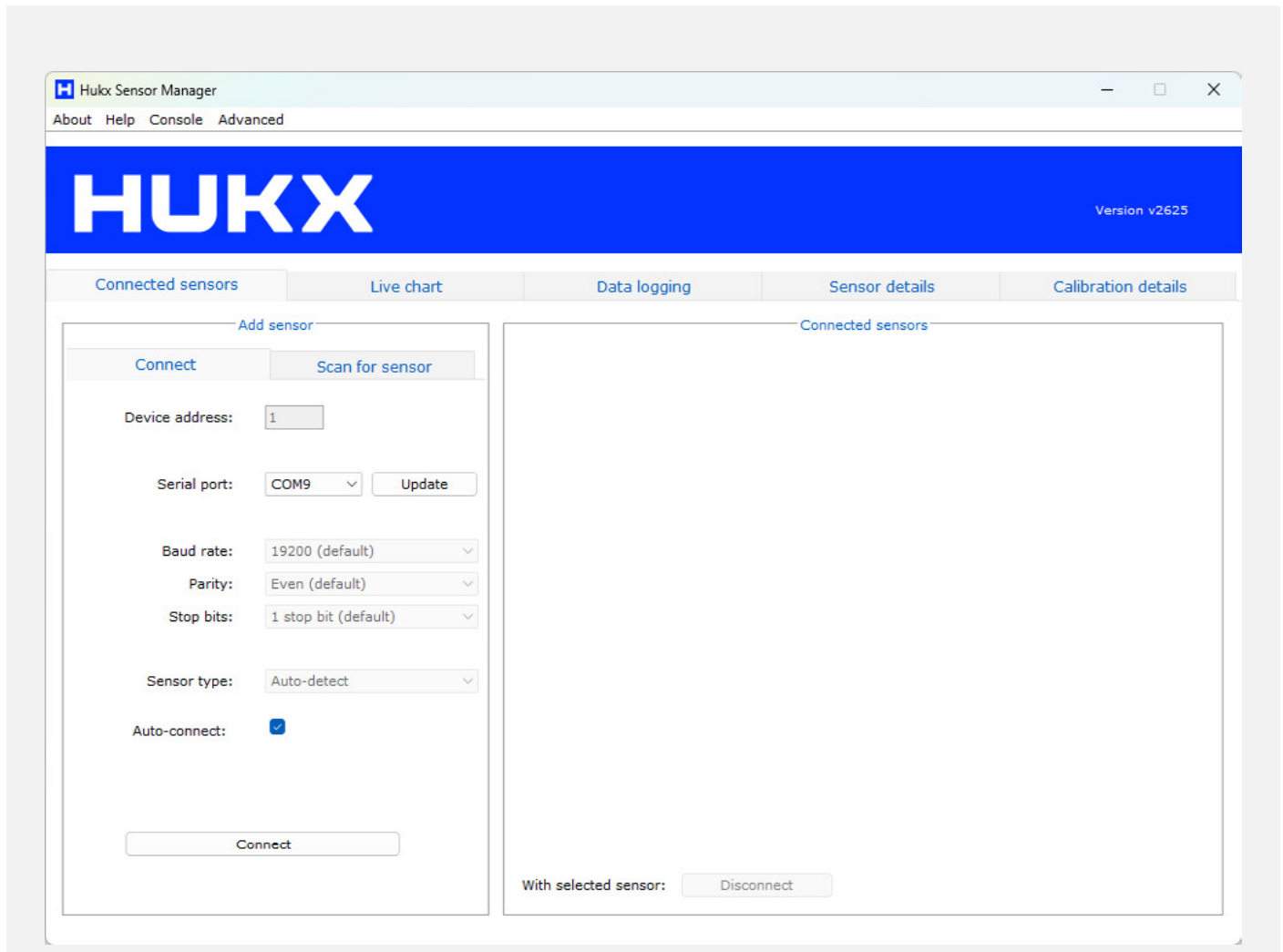

## Implementation in a SCADA network: programming manual and register lists

This manual gives directions for electrical connection and implementation in an RS-485 network. For programming, consult the separate "Programming manual industrial pyranometers and diffusometers" and the "register list" document for every instrument model for more details. These documents can be downloaded via [www.hukx.com/downloads](http://www.hukx.com/downloads)

## Optional accessories

We offer accessories for use with the SR300-D1, SR200-D1 and SR100-D1, including electrical and mounting hardware options.

- **SPD01** Surge Protection Device (for 1 to 3 instruments) for cables longer than 3 meters and to upgrade Surge Protection to level 4
- **PID01** Pyranometer Isolation Disc, electrically insulating the instrument from the mounting platform, spring-loaded for easy leveling
- **LM01** spring-loaded leveling mount; a practical mount for easy mounting, leveling, and instrument exchange on flat surfaces
- **TLM01** tube leveling mount with a set of bolts
- calibration certificate including customer name and contact information
- **DP01** dome protector, set of 5 pieces
- **AMF03** albedometer fixture
- **PMF01** and **PFM02** mounting fixtures



Figure 0.8 Examples of optional accessories for the most common ways to mount and level pyranometers, and also to electrically insulate them from their metal mounting platform.



Figure 0.9 LM01 leveling mount is the most popular option for pyranometers: practical spring-loaded mount for easy mounting, leveling and instrument exchange on flat surfaces. The spring-loaded mounting has the advantage that leveling can be done quickly, without unlocking the instrument.

## See also

- Consult our [pyranometer selection guide](#).
- Learn more about SR300-D1, SR200-D1, and SR100-D1 on [our YouTube channel](#).
- Understand the importance of [ventilating and heating pyranometers](#).
- View our complete [range of solar sensors](#).

# 1 Ordering and checking at delivery

## 1.1 Ordering industrial pyranometers

The standard configuration of industrial pyranometers is without a cable. Hukx industrial pyranometers can be ordered with a range of optional accessories including various mounting brackets or electrical accessories. See section on optional accessories for a complete list.

The order code consists of the instrument model optionally followed by the model for mounting brackets, optionally followed by a code for a cable. E.g. to order an SR300-D1 with TLM01 mounting bracket and 3 m cable the order code would be SR300-D1-TLM01-03. Other accessories can be ordered separately.

Order code:

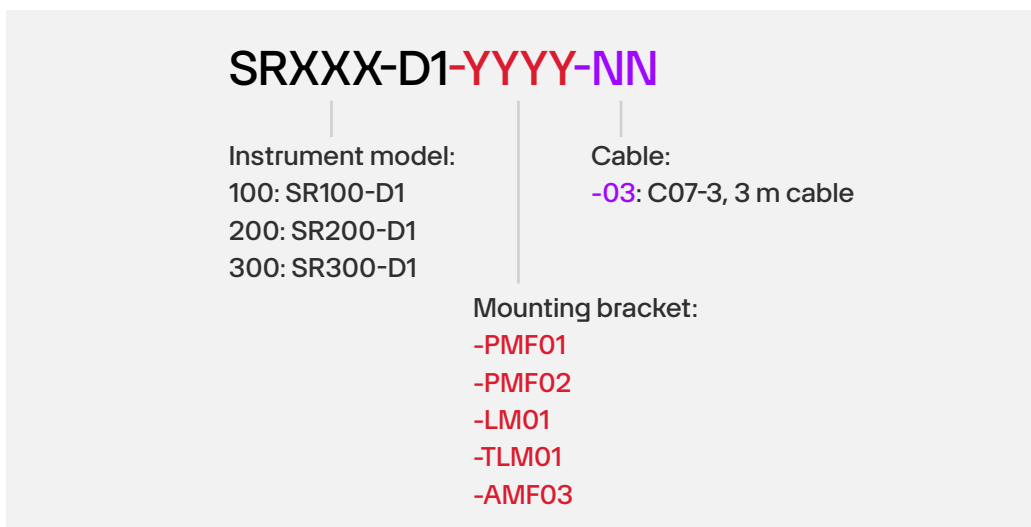

## 1.2 Included items

Arriving at the customer, the delivery should include:

- Hukx industrial pyranometer: SR300-D1, SR200-D1 or SR100-D1 as ordered
- sun screen
- dome protector
- leveling feet (1 x fixed + 2 x adjustable)
- certificates:
  - product certificate matching the instrument serial number
  - calibration certificate
  - for SR300-D1 and SR200-D1: test certificates of temperature response and directional response
  - for SR300-D1: test certificate of accelerometer
- uninsulated ring terminal with earth screw
- any other options as ordered

## 1.3 Quick instrument check

A quick check of the instrument can be done by connecting it to a PC and installing the Sensor Manager software. See the chapter on connection to a PC for directions. Note that a separate power supply is required—the instrument cannot be powered from a USB port.

1. At power-up, the solar irradiance signal may have a temporary output level different from zero—an offset. Let this offset settle down—it is a normal part of the power-up procedure. For SR300-D1 use the power and communication status LED.
2. Take the dome protector off. Check if the sensor reacts to light: expose the sensor to a strong light source, for instance a 100 W light bulb at 0.1 m distance. The signal should read  $> 100 \text{ W/m}^2$  now. Darken the sensor either by putting something over it or switching off the light. The instrument irradiance output should go down and within one minute approach  $0 \text{ W/m}^2$ .
3. Remove the sun screen, inspect the bubble level. For SR300-D1 compare to the tilt angle output (within  $1^\circ$  when bubble is entirely in ring).
4. Verify that the internal humidity indicator is not set (for new instruments internal humidity below 10 % at room temperature).
5. For SR300-D1: verify heater current, ventilator speed (between 4000 and 8000 RPM [Revolutions per Minute]).
6. Inspect the instrument for any damage (for new instruments scratches on domes may be checked according to ISO 10010: see the appendix on optical surface imperfections).
7. Check the instrument serial number, sensitivity, etc., programmed in the instrument as indicated by the Sensor Manager software against the label on the instrument and against the certificates provided with the instrument.

# 2 Instrument principle and theory

## 2.1 Instrument principle

A pyranometer is an instrument for measuring the solar irradiance on a plane surface, parallel to its black sensor surface. Irradiance is the radiant flux or radiant power incident on a plane of a given orientation per unit area. The S.I. units of irradiance are  $[W/m^2]$ . A pyranometer measures solar radiation received from a  $180^\circ$  field of view angle, referred to as hemispherical radiation.

If the plane of measurement is horizontal and facing up towards the sky, the irradiance is referred to as the global horizontal irradiance or GHI. If the plane is tilted, the irradiance is referred to as a global tilted irradiance or GTI. Measuring global tilted irradiance is common practice for PV monitoring purposes. In that case, the sensor measures in the plane of the PV array, and irradiance is called Plane of Array or POA.

The solar radiation spectrum extends roughly from 285 nm (UV) to 3000 nm (near infrared). By definition, a pyranometer should cover that spectral range with a spectral selectivity that is as "flat" as possible.

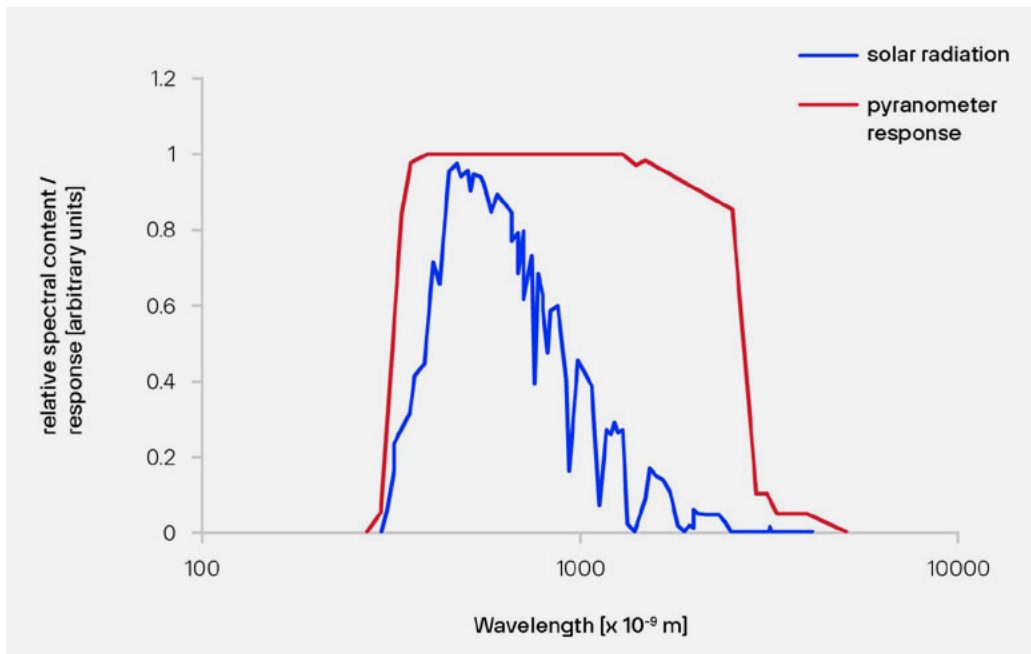

Figure 2.1.1 Spectral response of the pyranometer compared to the solar spectrum. The pyranometer only cuts off a negligible part of the total solar spectrum.

When measuring irradiance, the response to “beam” radiation should vary with the cosine of the angle of incidence on the black sensor surface. This is because whenever the plane surface intersects the beam at steeper angles, the radiant flux is spread out over a larger area resulting in a smaller irradiance. A pyranometer should have a so-called “directional response” that is as close as possible to the ideal cosine characteristic (older documents mention the term “cosine response” instead); i.e. ideally it should have full response when the solar radiation hits the sensor perpendicularly (normal to the surface, sun at zenith, 0 ° angle of incidence), zero response when the sun is at the horizon (90 ° angle of incidence, 90 ° zenith angle), and 50 % of full response at 60 ° angle of incidence.

To attain the proper directional and spectral characteristics, the main components of the Hukx industrial pyranometers are:

- A thermal sensor with black coating. It has a flat spectrum covering the  $(200 \text{ to } 50\,000) \times 10^{-9} \text{ m}$  range, and has a near-perfect directional response. The coating absorbs all solar radiation and, at the moment of absorption, converts it to heat. The heat flows through the thermopile sensor to the instrument body and from the instrument body to the environment. The thermopile sensor generates a voltage output signal that is proportional to the solar irradiance.
- A first (outer) glass dome. The dome acts as a spectral band-pass filter that transmits light in the spectral range from  $(285 \text{ to } 3\,000) \times 10^{-9} \text{ m}$  (cutting off the part above  $3\,000 \times 10^{-9} \text{ m}$ ), while preserving the 180 ° field of view angle. In addition, the dome shields the thermopile sensor from the environment (convection, rain).
- a second (inner) glass dome: SR300-D1, SR200-D1 and SR100-D1 pyranometers use two domes. This construction provides an additional “radiation shield”, resulting in a better thermal equilibrium between the sensor and inner dome, compared to using a single dome. The effect of having a second dome results in a strong reduction of instrument unwanted thermal offsets.

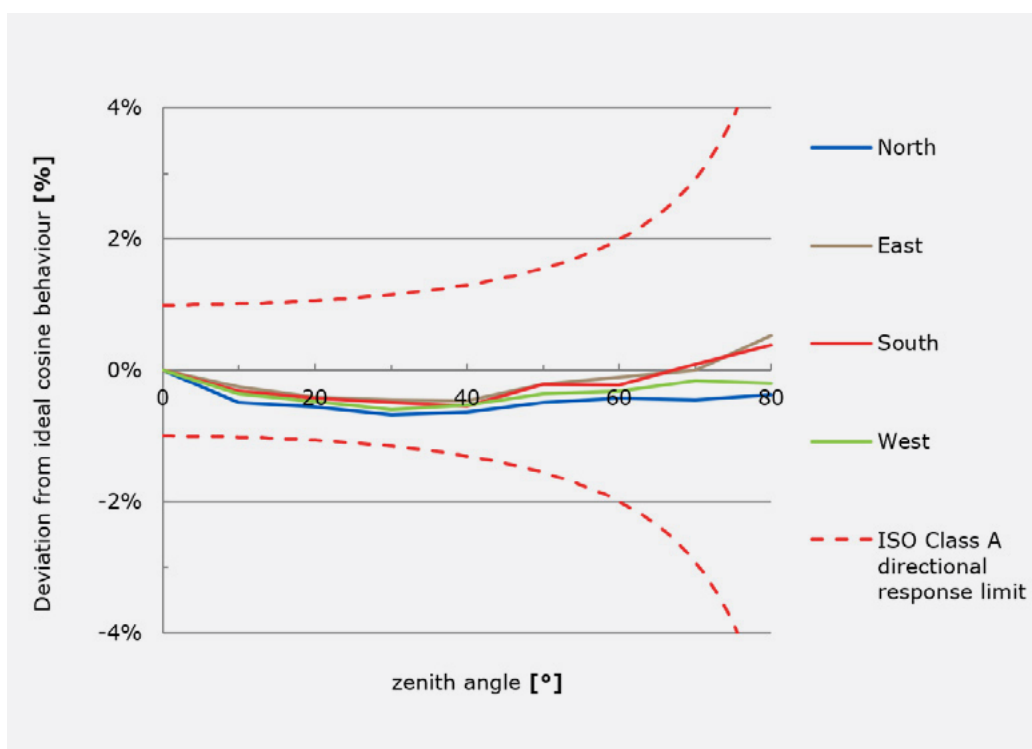

Figure 2.1.2 Example of a directional response of a SR200 pyranometer at 4 azimuth angles, compared to spectrally flat Class A (secondary standard) limits for the maximum directional error.

Modern pyranometers such as SR300-D1 often have additional features such as dew and frost mitigation to improve data availability and internal diagnostic sensors (for example for tilt, pressure and humidity) to verify that the instrument operates under the correct conditions.

## 2.2 ISO 9060:2018 pyranometer classification

Pyranometers are manufactured to different specifications and with different levels of verification and characterization during production. The ISO 9060:2018 standard, *"Solar energy—specification and classification of instruments for measuring hemispherical solar and direct solar radiation"*, distinguishes between 3 classes of pyranometers; Class A (highest accuracy), Class B (second highest accuracy) and Class C (third highest accuracy). The classification is based on the pyranometer response time, zero offsets, non-stability, nonlinearity, directional response, spectral error, temperature response, tilt response and additional signal processing errors (see appendix on pyranometer specifications for definitions). From Class C to Class B and from Class B to Class A, the practically achievable irradiance measurement accuracy improves roughly by a factor 2. Specifications are based on tests of the instrument design, but in the case of Class A, the instruments' directional response and temperature response must be tested by the manufacturer for every individual instrument.

## 2.3 Spectrally flat pyranometers

The spectral error of ISO 9060:2018 is defined as "Clear sky global horizontal irradiance spectral error". This error is valid under a clear sky on a sunny day only. Under other circumstances, for example when a cloud obscures the direct sun or under a cloudy sky, the measurement error with a normal Class A, B or C pyranometer is undefined. Depending on the pyranometer model, the errors can potentially be large under those circumstances.

In addition to the main classification of pyranometers, ISO 9060:2018 also defines a subclass, called "spectrally flat". The vast majority of users need to use instruments of the spectrally flat subclass—only spectrally flat instruments measure with high accuracy, also when a cloud obscures the sun, or when the irradiance includes reflected radiation. These situations occur, for example, when you measure Global Horizontal Irradiance (GHI) under partly or fully cloudy skies, when you measure Plane of Array (POA), albedo or net radiation. Instruments of just Class A, B or C, and not spectrally flat, only measure accurately under clear sky conditions.

Using “spectrally flat” instruments is essential because this ensures:

- You can measure accurately not only horizontally under clear-sky conditions, but also general GHI, POA, albedo and net radiation.
- You comply with WMO requirements—the spectrally flat subclass also means the instrument complies with WMO guide and keeps continuity with the 1990 version of ISO 9060.
- You can use the normal standardised ISO and WMO calibration procedures.
- You can also measure separately the diffuse component only (creating a diffusometer) with a shadow ring or shading ball, using the same instrument model.
- You can perform uncertainty evaluations with negligible (zero) spectral errors.

# 3 Specifications

## 3.1 General overview

This section provides a brief overview of the Hukx industrial pyranometers.

### Instrument purpose and intended use

A pyranometer measures the solar radiation received by a plane surface from a 180 ° field of view angle. This quantity, expressed in [W/m<sup>2</sup>], is called "hemispherical" solar radiation. It is intended for ground-based outdoor measurements in all climate types.

Measurement specifications are valid for clean instruments under the rated operating conditions.

Pyranometers must be part of a larger system which collects and stores data. This system must preserve the rated operating conditions of the pyranometer.

Pyranometers are classified according to ISO 9060. Depending on the application they should be employed and maintained in accordance with the recommended practices of ISO, IEC, WMO and ASTM.

### General instrument specifications & compliance

	SR300-D1	SR200-D1	SR100-D1
ISO 9060:2018 classification	spectrally flat Class A	spectrally flat Class A	spectrally flat Class B
ISO 9060:1990 classification	secondary standard	secondary standard	first class
WMO performance level (WMO-No. 8, 2023 edition)	high quality	high quality	good quality
IEC 61724-1:2021 compliance for solar irradiance measurement	meets Class A PV monitoring system requirements  for all locations and climatic conditions	meets Class A PV monitoring system requirements  for locations where dew and frost is expected for < 2 % of annual GHI hours	meets Class B PV monitoring system requirements  for all locations and climatic conditions
IEC 61724-1:2021 compliance for single axis tracker and pyranometer tilt angle measurement	meets Class A PV monitoring system requirements	-	-

## Instrument diagnostics

	SR300-D1	SR200-D1	SR100-D1
<b>on-site diagnostics</b>			
power and communication status LED	•	-	-
<b>remote diagnostics alerts</b>			
high internal humidity	•	-	-
instrument leakage	•	-	-
change of tilt	•	-	-
change of rotation	•	-	-
change of tilt x	•	-	-
change of tilt y	•	-	-
heating and ventilation malfunction	•	-	-
<b>remote diagnostics measurements</b>			
instrument body temperature	•	•	•
internal humidity	•	•	•
instrument tilt	•	-	-
instrument rotation	•	-	-
instrument tilt x	•	-	-
instrument tilt y	•	-	-
internal pressure	•	-	-
heater current	•	-	-
ventilator current	•	-	-
ventilator speed	•	-	-

## 3.2 Rated operating conditions

Hukx industrial pyranometer models are tested for a wide range of operating conditions. To avoid permanent damage to the instrument, guarantee reliable operation and measure accurately the instrument must be operated within the range of conditions listed below. These conditions are referred to as 'rated operating conditions'. In addition to this, the instrument must be kept clean. Suggestions for a maintenance schedule can be found in the standards in chapter 4 and in chapter 7.

### Rated operating conditions

#### calibration

interval	< 5 years recommended calibration interval is 2 years, as recommended by ISO TR 9901 and required by IEC 61724-1 Class A
----------	---

#### environmental

operating temperature range	(-40 to +80) °C
-----------------------------	-----------------

#### electrical

operating voltage	(8 to 30) VDC
-------------------	---------------

#### other

internal relative humidity	< 40 %
----------------------------	--------

#### NOTICE

Measure with a clean instrument and under the rated operating conditions only.  
Working outside rated operating conditions may lead to loss of measurement accuracy, loss of data or permanent damage.

### 3.3 Pyranometer specifications and classification

For the definition of the ISO 9060 pyranometer classification parameters, see the appendix. The pyranometers meet or exceed the criteria set by the ISO 9060:2018 standard for the respective instrument class.

Pyranometer specification according to ISO 9060:2018			
parameter	SR300-D1	SR200-D1	SR100-D1
response time (95 %)	3 s †*	3 s †*	3 s *
zero offset a (response to 200 W/m <sup>2</sup> net thermal radiation):			
– dew and frost mitigation mode, or normal power mode	< 2 W/m <sup>2</sup> *	N/A	N/A
– high accuracy mode, or medium power mode	< 2 W/m <sup>2</sup> *	N/A	N/A
– power saving mode, or low power mode	< 5 W/m <sup>2</sup> *	< 5 W/m <sup>2</sup> *	< 5 W/m <sup>2</sup> *
zero offset b (response to 5 K/h change in ambient temperature)	< ± 2 W/m <sup>2</sup>	< ± 2 W/m <sup>2</sup>	< ± 2 W/m <sup>2</sup> *
zero offset c (total zero offset):			
– dew and frost mitigation mode, or normal power mode	< 5 W/m <sup>2</sup> *	N/A	N/A
– high accuracy mode, or medium power mode	< 5 W/m <sup>2</sup> *	N/A	N/A
– power saving mode, or low power mode	< 8 W/m <sup>2</sup> *	< 8 W/m <sup>2</sup> *	< 8 W/m <sup>2</sup> *
non-stability	< ± 0.5 % / 5 yrs *	< ± 0.5 % / 5 yrs *	< ± 0.5 % / 5yrs *
non-linearity (100 to 1000) W/m <sup>2</sup>	< ± 0.2 % *	< ± 0.2 % *	< ± 0.2 % *
directional response	< ± 10 W/m <sup>2</sup> †	< ± 10 W/m <sup>2</sup> †	< ± 20 W/m <sup>2</sup>
spectral selectivity (0.35 to 1.5) x 10 <sup>-6</sup> m (for subclassification "spectrally flat" only)	< ± 3 %	< ± 3 %	< ± 3 %
clear sky global irradiance spectral error	< ± 0.5 %	< ± 0.5 %	< ± 0.5 % *

## Pyranometer specification according to ISO 9060:2018

parameter	SR300-D1	SR200-D1	SR100-D1
temperature response (-30 to +50 °C)	< ± 0.4 % †*	< ± 0.4 % †*	< ± 2.0 %
tilt response (0 to 90 ° at 1000 W/m <sup>2</sup> )	< ± 0.2 % *	< ± 0.2 % *	< ± 0.2 % *
additional signal processing error	none * (signal processing errors are included in other specifications)		

† Property is tested on an individual basis and corresponding results are reported on the product certificate included with each instrument.

\* The instrument outperforms the minimum requirements set by the ISO 9060:2018 standard for the corresponding class.

### NOTICE

SR300-D1 does not comply with ISO 9060 Class A criteria when the heater is switched on while the ventilator is switched off (invalid mode).

See the appendix on ISO and WMO classification tables for the comparison of the above specifications to ISO 9060.

## Additional pyranometer specifications

spectral range (20 % transmission points)	(285 to 3000) x 10 <sup>-9</sup> m
limiting irradiance range	-400 to 4000 W/m <sup>2</sup>
field of view angle	180 °
leveling (see options)	Bubble level and adjustable leveling feet are included.
leveling accuracy	< 0.1 ° when the bubble is entirely within the ring.

### 3.4 Electrical specifications

Hukx industrial pyranometers require external power to operate. Industrial pyranometers have an isolated RS-485 hardware interface for communication. The instruments have an M12-A connector for connection to a power supply and an RS-485 network, as well as a dedicated earthing point to connect the instrument body to protective earth (PE). Earthing of the instrument is achieved through the earthing terminal which is electrically connected to the instrument body and the connector housing. The connector housing also provides an earthing point to the cable shield.

#### Electrical connection, earthing and isolation

rated operating supply voltage	(8 to 30) VDC
recommended operating voltage	24 VDC
recommended over-current protection	< 1 A slow-blow fuse *
reverse polarity protection	included
hardware interface	2-wire RS-485, separate signal ground wire
RS-485 common mode range	(-7 to +12) V
RS-485 differential mode range	(-7 to +12) V
RS-485 isolation voltage	1.5 kV (DC for 1 minute)
RS-485 needs fail-safe biasing (line polarization)	yes**
implements fail-safe biasing (line polarization)	no
earthing terminal	M5 x 6 mm threaded hole in instrument body
conductor cross-section with included ring terminal	≤ 4 mm <sup>2</sup> or ≤ 12 AWG
recommended maximum cable length	≤ 100 m ***

\* More information about current over protection can be found under "cabling and surge protection".

\*\* Only for SR300-D1 with serial numbers up to 51179, SR200-D1 with serial numbers up to 32684 and SR100-D1 with serial numbers up to 15749, for higher serial numbers there is no such requirement as these instruments are intrinsically fail-safe.

\*\*\* In practice the system design, environmental factors, data communication speed, required operating voltage, use of additional SPD's, etc. will determine possibilities for cable extension. More information can be found under "cabling and surge protection".

Hukx industrial pyranometers are optionally supplied with a cable with one connector and one free cable end. The cable specifications are listed below.

## Cable specifications

available lengths for optional cables	3, 5, 10 or 20 m
conductor cross-section	0.25 mm <sup>2</sup> (24 AWG) stranded copper conductors
number of conductors	5
cable shield	braided
cable outer diameter	4.8 mm
connector	M12 A-coded socket connector, 5-pole
cable termination	removed sheath over 0.15 m, stripped ends with ferrules

SR300-D1 can be operated in three different power modes. This allows users of SR300-D1 to save power while still making use of the advantages of SR300-D1 over the other models. For SR300-D1, performance in all valid modes complies with ISO 9060 Class A classification criteria.

## Power consumption

	SR300-D1	SR200-D1	SR100-D1
normal power mode, heated and ventilated (corresponds to dew and frost mitigation mode)	< 3.0 W*	N/A	N/A
medium power mode, unheated and ventilated (corresponds to high accuracy mode)	< 1.0 W	N/A	N/A
low power mode, unheated and unventilated (corresponds to power saving mode)	< 0.5 W	< 0.5 W	< 0.5 W

\* at 100 % heater duty cycle.

Hukx industrial pyranometers are suitable for use in industrial environments such as PV power plants. The instruments meet industrial-level EMC requirements and have been designed to withstand electrical surges. EMC specifications and surge immunity specifications are listed below.

## EMC specifications\*

emission	EN-IEC 61326-1:2013 EN-IEC 61326-1:2021
emission limits applied	EN 55011, Class A and B FCC, part 15, Class A and B
electromagnetic environment (IEC 61326-1)	industrial
immunity	EN-IEC 61326-1:2013 EN-IEC 61326-1:2021 EN-IEC 61000-6-2:2019
<b>applicable EMC test levels</b>	
electrostatic discharge (EN-IEC 61000-4-2:2009)	level 4 ± 15 kV air discharge, ± 8 kV contact discharge
electromagnetic field (EN-IEC 61000-4-3:2020)	level 3 10 V/m (80 MHz to 1 GHz) 3 V/m (1.4 GHz to 6 GHz)
burst (EFT) (EN-IEC 61000-4-4:2012)	level 3 ± 2 kV with a capacitive clamp at 5 and 100 kHz
surge (EN-IEC 61000-4-5:2014+A1:2017)	level 2 ± 1 kV, line-to-ground, all lines tested as I/O lines
conducted RF (EN-IEC 61000-4-6:2014)	level 3 10 V/m

\* Tested assuming shielded cable  
(shield connected at both ends)  
with a maximum length of 20 m.

## Surge test conditions (EN-IEC 61000-4-5:2014+A1:2017)

surge immunity	level 2
surge test level	± 1 kV line-to-ground
coupling network	40 Ω / 0.5 μF
cable	see section on cable specifications
earthing	<ul style="list-style-type: none"><li>– pyranometer earthing terminal</li><li>– cable shield on pyranometer's side</li><li>– cable shield connected or disconnected at one or both ends</li></ul>

### surge test conditions with optional SPD01

surge immunity	level 4
surge test level	± 4 kV line-to-ground ± 2 kV line-to-line
coupling network	18 μF
cable section SPD to pyranometer	shielded and ≤ 3 m, see section on cable specifications
cable section SCADA system to SPD	shielded or unshielded*, length not specified
earthing	<ul style="list-style-type: none"><li>– pyranometer earthing terminal</li><li>– SPD earthing terminal</li><li>– pyranometer cable shield, on both sides</li></ul>

\* Cable shield disconnected at one or both ends.

Hukx industrial pyranometers act as a Modbus RTU server that must be combined with a data acquisition system that can act as a Modbus RTU client. The server and client must be configured to have the same serial settings.

## Digital communication

communication protocol	Modbus
transmission mode	RTU
BAUD rate settings	9600, 19200, 38400, 115200
data bits	8
parity bits	none (N), even (E), odd (O)
stop bits	1, 2
default serial settings	19200 bits/s, 8 data bits, even parity, 1 stop bit (19200 8E1)
default device address	1
auto-connect serial settings	9600 8E1
boot up time after power reset	8 s
register address configuration	<ul style="list-style-type: none"> <li>– SR300-D1: available from firmware version v1.9.0 onwards</li> <li>– SR200-D1: available from firmware version v1.8.0 onwards</li> <li>– SR100-D1: available from firmware version v1.8.0 onwards</li> </ul>

### 3.5 Environmental

Environmental	
rated operating temperature range (IEC 60068-2-14)	(-40 to +80) °C
operating relative humidity range (IEC 60068-2-78)	(0 to 100) %
exposure to liquids and dust IEC 60529 Ingress Protection class	IP67
corrosion resistance	SAE J2334

### 3.6 Weight and dimensions

Mechanical	
connector	M12-A plug connector, 5-pole
earthing terminal	earthing terminal M5, M5x8 bolt included, 4 mm <sup>2</sup> M5 ring terminal included
mounting	– 2 x M5 bolt at 46 mm center-to-center distance on north-south axis, maximum insertion depth of 6 x 10 <sup>3</sup> m, requires 4 mm hex key (not included) – 1 x M6 bolt, centered, maximum insertion depth of 6 x 10 <sup>3</sup> m
housing material	anodized aluminum
dome material	optical glass, N-BK7
dome protector	included (1 x model DP01)
nett weight excluding cable	0.65 kg
gross weight excluding cable	0.7 kg
packaging note: cable not included	box of (215 x 152 x 108) mm

#### NOTICE

Do not turn bolts into the holes beyond the maximum insertion depth.

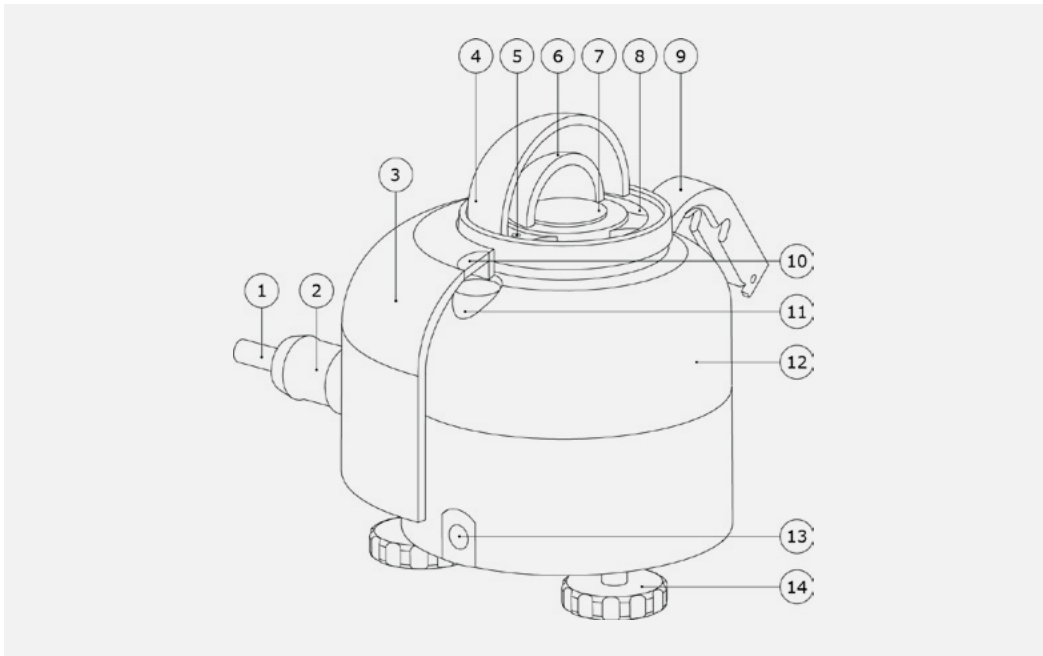

**Figure 3.6.1** Hukx industrial pyranometers components:

- 1. signal and power cable
- 2. 5-pole M12-A connector
- 3. sun screen
- 4. outer dome
- 5. status LED (SR300-D1 only)
- 6. inner dome
- 7. thermal sensor with black coating
- 8. internal ventilation vents (SR300-D1 only)
- 9. quick release system of the sun screen
- 10. bubble level window
- 11. bubble level
- 12. instrument body
- 13. earthing terminal
- 14. leveling feet (1 x fixed, 2 x adjustable)

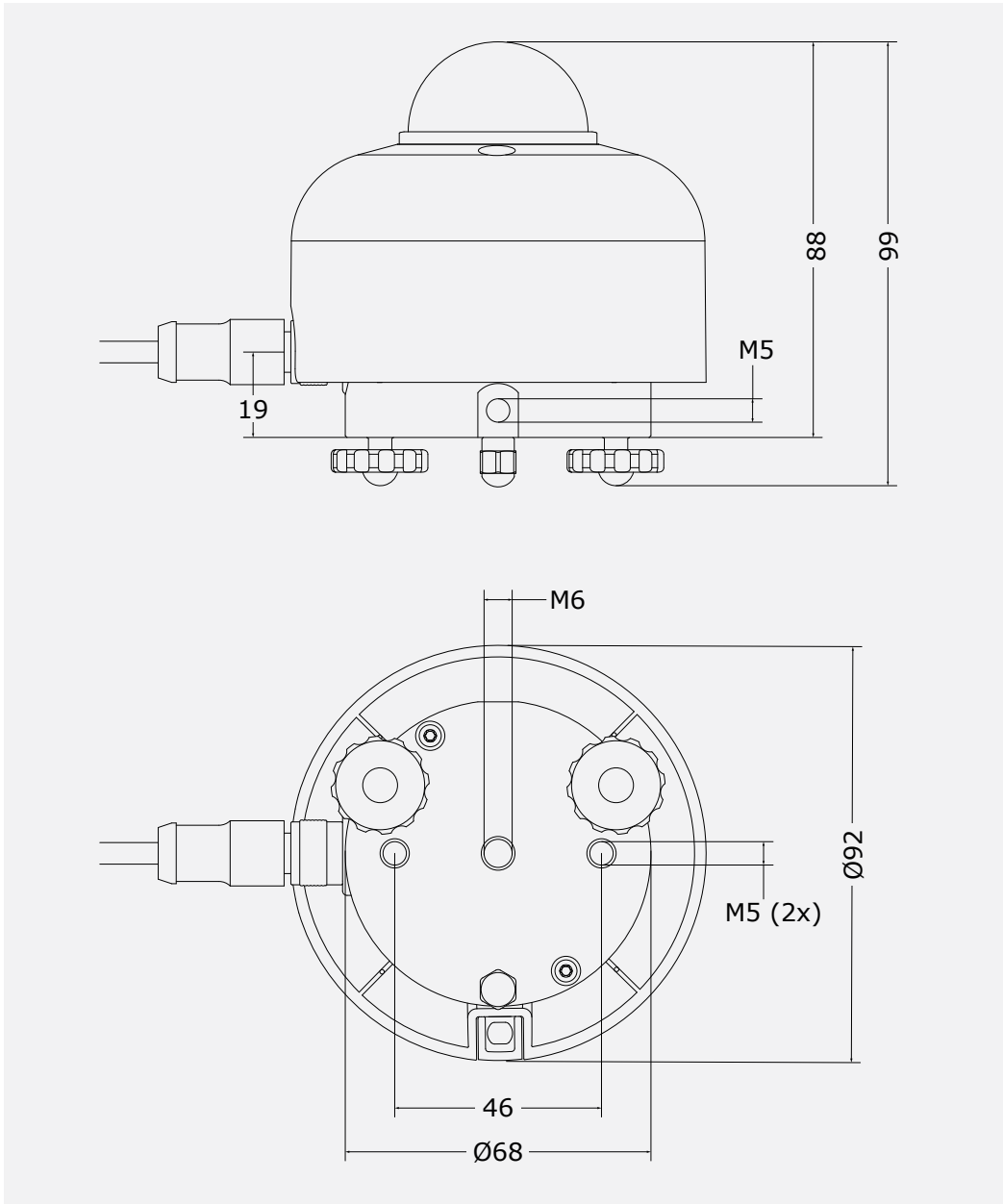

**Figure 3.6.2** Dimensions of Hukx industrial pyranometers.

## 3.7 Optional accessories

The table provides an overview of accessories that are compatible with the Hukx industrial pyranometers.

<b>Accessories</b>	
<b>mounting</b>	
PMF01—Pyranometer Mounting Fixture	Pyranometer mounting fixture for 1 pyranometer, horizontal or tilted
PMF02—dual Pyranometer Mounting Fixture	Pyranometer mounting fixture for 2 pyranometers, horizontal and tilted
LM01—Leveling Mount	Spring-loaded mounting fixture for easy leveling of a pyranometer
TLM01—Tube Leveling Mount	For easy mounting and leveling of pyranometers on a tube
AMF03—Albedo Mounting Fixture	Mounting fixture for combining an upward and a downward facing pyranometer, to construct an albedometer
CMF01—Crossarm Mounting Fixture	Crossarm mounting fixture for pyranometers, albedometers and net radiometers
<b>electrical</b>	
C07-03	3 m, 24 AWG, 5-pole cable with shielding, one M12-A socket connector and one free cable end
C07-05	5 m, 24 AWG, 5-pole cable with shielding, one M12-A socket connector and one free cable end
C07-10	10 m, 24 AWG, 5-pole cable with shielding, one M12-A socket connector and one free cable end
C07-20	20 m, 24 AWG, 5-pole cable with shielding, one M12-A socket connector and one free cable end
C07-C04E F-M	5-pole M12-A socket connector to 10-pole M16 plug connector adapter cable, for convenient replacement of SR20-D2 by industrial series instrument
SPD01—Surge Protection Device	Surge protection device
PID01—Pyranometer Insulation Disc	Electrically insulating disc for insulating the pyranometer housing from its mounting platform, including spring loaded fixation for easy leveling

## Accessories

### software

HSM—Hukx Sensor Manager

Free of charge software for use with a PC. Useful for configuring digital Hukx industrial pyranometers.

### miscellaneous

DP01—set of 5 Dome Protectors

Cover for protecting a pyranometer dome during storage, installation and transport. Set of 5 pieces.

SCR07—Sun screen

White sun screen to prevent the instrument body from being exposed to solar radiation.

LF01

2 x adjustable leveling feet and 1 x static foot for horizontal installation of the instrument.

SF01

Static feet for tilted installation of the instrument, set of 3.

glare screen

Glare screen for limiting field of view angle by 5 °, from a full field of view angle of 180 ° to 170 ° when installing the instrument in inverted horizontal position.

### 3.8 Measurands, certificates and calibration

Hukseflux industrial pyranometers are used to measure instantaneous hemispherical solar radiation as well as statistical information such as average, min/max and standard deviation, all in  $[W/m^2]$ , over a certain read-out interval. From the average and the read-out interval, the user can also calculate time-integrated irradiance (radiant exposure) in  $[W \cdot h/m^2]$ . Hemispherical solar radiation may be Global Horizontal Irradiance (GHI), Global Tilted Irradiance (GTI) or Plane of Array (POA) irradiance and Ground Reflected Irradiance. The instrument may also be used to measure albedo (requires two instruments), sunshine duration (requires a real time clock and post processing of measurement data) and Diffuse Horizontal Irradiance (DHI) (requires the instrument to be shaded from direct sunlight, e.g. using a solar tracker with a shading ball or a shading band). See the chapter on recommended practice for use for more details. The instrument body temperature is measured to perform temperature compensation for the irradiance as well as tilt.

Irradiance measurement	
<b>measurand</b>	instantaneous hemispherical solar radiation
measurand in SI radiometry units	irradiance in $W/m^2$
uncertainty of the measurement	Statements about the overall measurement uncertainty can only be made on an individual basis. See the appendix on uncertainty evaluation.
statistical information	on hemispherical solar radiation: <ul style="list-style-type: none"> <li>– average</li> <li>– min/max</li> <li>– standard deviation</li> </ul>
output in SI radiometry units	irradiance in $W/m^2$
measurement interval for statistical information	read-out interval (statistical parameters are reset to zero at the moment of read-out of the register)
<b>use of the measurand</b>	<p>Measurements can be used for the quantities:</p> <ul style="list-style-type: none"> <li>– Global Horizontal Irradiance</li> <li>– Global Tilted Irradiance or Plane of Array irradiance</li> <li>– Ground Reflected Irradiance</li> <li>– Diffuse Irradiance (requires the instrument to be shaded from direct sunlight, e.g. using a solar tracker with a shading ball or a shading band)</li> </ul> <p>Measurements may also be used as input quantity to calculate:</p> <ul style="list-style-type: none"> <li>– Time-integrated solar irradiance or radiant exposure in <math>[W \cdot h/m^2]</math>. Calculated by the user: average multiplied by read-out interval</li> <li>– Albedo (requires 2 instruments)</li> <li>– Sunshine duration (requires a real-time clock and some post-processing)</li> </ul>

## Irradiance measurement

<b>input quantity</b>	instrument body temperature
instrument body temperature measurement uncertainty	$\pm 0.5 \text{ }^{\circ}\text{C}$
instrument body temperature resolution	$7.8 \times 10^{-3} \text{ }^{\circ}\text{C}$

SR300-D1 includes an accelerometer that can be used to measure the instrument orientation: tilt and rotation angles. The tilt measurement can be used to detect undesired changes in orientation when the instrument is mounted in a fixed orientation or to track the orientation of the instrument when mounting the instrument on a solar tracker.

### NOTICE

The instrument is rated for operation under static conditions. Any movement or vibration may impact the accuracy of the accelerometer measurements.

## Orientation measurement (SR300-D1 only)

<b>measurand</b>	instrument tilt angle
tilt reference	horizontal corresponds to $0^{\circ}$
tilt measurement uncertainty	$\pm 1^{\circ}$ (-30 to +50) $^{\circ}\text{C}$
tilt measurement range	(0 to 180) $^{\circ}$
tilt sensor detection limit	$< 0.1^{\circ}$
<b>measurand</b>	instrument rotation angle (for non-horizontal instruments only)
rotation reference	connector up corresponds to $0^{\circ}$
rotation measurement range	(-180 to +180) $^{\circ}$
rotation measurement uncertainty	$\pm 2^{\circ}$ at $45^{\circ}$ instrument (zenith) tilt angle and (-30 to +50) $^{\circ}\text{C}$
tilt range for rotation output	angle of the z-axis with zenith (zenith tilt) from (5 to 175) $^{\circ}$ †

## Orientation measurement (SR300-D1 only)

<b>measurand</b>	instrument tilt x angle*
tilt x reference*	horizontal corresponds to 0 °
tilt x measurement range*	(-180 to +180) °
tilt x measurement uncertainty*	± 2 ° at 45 ° instrument (zenith) tilt angle and (-30 to +50) °C ± 1 ° for situations where tilt y is close to 0 ° or ± 180 ° and (-30 to +50) °C
range for tilt x output*	angle of the x-axis with zenith from (5 to 175) °
<b>measurand</b>	instrument tilt y angle* (for instruments where the y-axis is not parallel to zenith only)
tilt y reference*	horizontal corresponds to 0 °
tilt y measurement range*	(-180 to +180) °
tilt y measurement uncertainty*	± 2 ° at 45 ° instrument (zenith) tilt angle and (-30 to +50) °C ± 1 ° for situations where tilt x is close to 0 ° or ± 180 ° and (-30 to +50) °C
range for tilt y output*	angle of the y-axis with zenith from (5 to 175) °
<b>measurand</b>	x, y and z components of gravitational acceleration
axes reference	x axis: parallel to the measurement plane, in line with connector y axis: parallel to the measurement plane, in line with earthing terminal z axis: perpendicular to the black irradiance sensor surface, upward through the glass dome
acceleration measurement range	(-2 to +2) g
acceleration measurement uncertainty	± 0.018 g

\* for firmware version 1.9.0 and above

† for firmware version 1.6.0 and above

Hukx industrial pyranometers are supplied with a calibration certificate as well as the appropriate test reports.

## Certificates and reports

	<b>SR300-D1</b>	<b>SR200-D1</b>	<b>SR100-D1</b>
calibration certificate	•	•	•
product certificate confirming verification of specifications and classification	•	•	-
temperature response test of individual instrument report	•	•	-
directional response test of individual instrument report for 0 to 95 ° angle of incidence	•	•	-
accelerometer calibration of individual instrument report	•	-	-

Specifications for factory calibration can be found in the table below.  
 New instruments are provided with factory calibrations. A new calibration, as specified below, is available upon request.

Calibration	SR300-D1	SR200-D1	SR100-D1
uncertainty (k = 2)	< 1.2 %	< 1.2 %	< 1.8 %
traceability	To WRR		
hierarchy	From WRR through ISO 9846 and ISO 9847, applying a correction to reference conditions.		
method	indoor calibration according to ISO 9847, Type A1		
level of accreditation	ISO/IEC 17025:2017		
certificate content	Hukx issues calibration certificates with content limited as per ISO/IEC 17025, section 7.8.1.3. Such a certificate contains the calibration result, an uncertainty, a description of the calibration procedure and the traceability. As an option, a certificate including name and contact information of the customer may be ordered.		
rated calibration interval	< 5 years recommended calibration interval is 2 years, as recommended by ISO TR 9901 and required by IEC 61724-1 Class A		
reference conditions	20 °C, normal incidence solar radiation, horizontal mounting, irradiance level 1000 W/m <sup>2</sup> . For SR300-D1: medium power mode i.e. heater [OFF] and ventilator [ON].		
validity of calibration	Based on experience the instrument sensitivity will not change during storage. During use under exposure to solar radiation the instrument "non-stability" specification is applicable. The starting date of installation in the field may be used as starting date for the calibration interval.		
calibration records history and metadata	Records of the present calibration result and previous calibration results are stored in the instrument memory, including sensitivity, date of calibration and calibration traceability.		
the data structure is prepared for the expected WRR calibration scale shift	A metadata calibration traceability value of "0" denotes traceability to WRR. Consult Appendix 8.3 for more details on calibration traceability.		
recalibration: right to change pyranometer sensitivity	When recalibrating digital instruments, the new sensitivity and calibration date must be entered into the pyranometer memory. Owners of Hukx brand digital pyranometers as well as any of its subcontractors have permission to—and will get all necessary support for—changing the sensitivities of purchased instruments over the entire life of these instruments.		

# 4 Standards and recommended practices for use

Pyranometers are classified according to the ISO 9060 standard and the WMO-No. 8 Guide. Depending on the application, the instrument may be used in accordance with the recommended practices of ISO, IEC, WMO and/or ASTM.

## 4.1 Classification standards

**Table 4.1.1** Standards for pyranometer classification. See the appendix for definitions of pyranometer specifications, and a table listing the specification limits.

Standards for instrument classification		
ISO standard	Equivalent ASTM standard	WMO
ISO 9060:2018 <i>Solar energy—specification and classification of instruments for measuring hemispherical solar and direct solar radiation</i>	not available	WMO-No. 8 <i>Guide to Meteorological Instruments and Methods of Observation</i> , Volume 1, Measurement of Meteorological Variables, 2023 edition, Chapter 7, measurement of radiation, 7.3 measurement of global and diffuse solar radiation

## 4.2 General rules for solar radiation measurement

Table 4.2.1 Standards with recommendations for instrument use in solar radiation measurement.

Standards for instrument use for hemispherical solar radiation		
ISO standard	Equivalent ASTM standard	WMO
ISO/TR 9901:2021 <i>Solar energy—Pyranometers—Recommended practice for use</i>	ASTM G183–15R23 <i>Standard Practice for Field Use of Pyranometers, Pyrheliometers and UV Radiometers</i>	WMO-No. 8 <i>Guide to Meteorological Instruments and Methods of Observation, Volume 1, Measurement of Meteorological Variables, 2023 edition, Chapter 7, measurement of radiation, 7.3 measurement of global and diffuse solar radiation</i>  Baseline Surface Radiation Network, BSRN Operations Manual ( WMO / TD No 1274, L. J. B. McArthur, April 2005)

### 4.3 Specific use for PV system performance testing

IEC has issued a series of three standards for PV system performance testing.

- IEC 61724-1, "*monitoring*" giving requirements for measuring.
- IEC TS 61724-2 "*capacity evaluation method*" defining performance analysis based on the monitoring data over a short period of several sunny days, typically during commissioning and typically to verify if the system meets specification.
- IEC TS 61724-3 "*energy evaluation method*" defining performance analysis based on the monitoring data over a long period of 1 year or longer.

Pyranometers are used for monitoring PV power plant efficiency, in order to measure incoming solar radiation independently from the PV system. Pyranometers can be placed in four orientations:

- Plane of Array (POA), parallel to the PV panels, for measurement of the in-plane irradiance (also noted as  $G_i$  in IEC 61724-1).
- Horizontally, for measurement of the Global Horizontal Irradiance (GHI).
- Downfacing horizontally to measure Reflected Horizontal Irradiance (RHI).
- Downfacing in POA to measure in-plane rearside irradiance. (noted as  $G_i^{\text{rear}}$  or  $POA^{\text{rear}}$  in IEC 61724-1).

SR300-D1, SR200-D1 and SR100-D1 are suitable for measurement in all these four orientations.

At the location of all POA measurements, IEC 61724-3, clause 5 requires measurement of the local albedo to verify that it is representative of the albedo of the total power plant, and if it is within the range required for valid modelling. For monofacial modules the albedo measurement is used in the uncertainty evaluation of the performance test.

In case bifacial modules are used, the rearside solar irradiance may

- Be directly measured.
- Be estimated using an optical model from GHI, albedo, and optionally diffuse irradiance.

The contribution of reflected radiation to system performance is typically small. For the measurement of reflected radiation, lower accuracy Class C pyranometers may be used.

SR300-D1 also includes an accelerometer that can be used to measure instrument tilt. For PV systems with single-axis trackers, IEC 61724-1 Class A systems also require a tilt angle measurement. Every SR300-D1 accelerometer is individually calibrated and temperature compensated between (-30 and +50 °C), resulting in a high measurement accuracy of  $< \pm 1^\circ$ , meeting the requirement by IEC 61724-1 for class A systems.

Table 4.3.1 Standards with recommendations for instrument use in PV system performance testing.

Standards on pv system performance testing	
IEC / ISO standard	Equivalent ASTM standard
<p>IEC 61724-1 <i>Photovoltaic system performance monitoring—guidelines for measurement, data exchange and analysis</i>                      SR300-D1 complies with its standard configuration, with the IEC 61724-1:2021 requirements of Class A PV monitoring systems for solar irradiance for all locations and climatic conditions and for tracker tilt angle measurements.</p>	<p>ASTM E2848-13 <i>Standard Test Method for Reporting Photovoltaic Non-Concentrator System Performance</i></p>
<p>COMMENT: IEC 61724-1 allows the use of pyranometers or reference cells according to IEC 60904-2 and -6. For IEC 61724-1, pyranometer calibration uncertainty must be better than 2 % (Paragraph 8.2.2), tilt alignment within 1 ° tilt (Paragraph 8.2.8). Tracker tilt measurement shall be performed with ± 1 ° accuracy.</p>	<p>COMMENT: confirms that a pyranometer is the preferred instrument for outdoor PV testing. Specifically recommends a “first class” pyranometer (now spectrally flat class B in ISO 9060:2018) pyranometer (Paragraph A 1.2.1.)</p>
<p>For GHI and POA measurements, IEC 61724-1 allows the use of pyranometers without dew and frost mitigation (heating) in Class A systems, for locations where dew and frost are expected for less than 2 % of annual GHI hours. Under those conditions, SR200-D1 also complies.*</p>	
<p>IEC allows the use of ISO 9060 Class B or C pyranometers for RHI and POA<sup>rear</sup> measurements, in IEC 61724-1 Class A monitoring systems. For these measurements, SR100-D1 also complies.</p>	
<p>IEC 61724-1 requires that pyranometers in Class A monitoring systems are cleaned every week (unless it can be proven this is not necessary) and calibrated every 2 years.</p>	
<p>* IEC 61724-1:2021 comments: determination of whether an installation site requires mitigation, may be performed by examining typical meteorological year data for the site, paying attention to ambient temperature and dew point. For the purpose of this assessment, dew or frost is considered expected when ambient temperature is within 1.5 °C of dew point.</p>	

## 4.4 Specific use in meteorology and climatology

The World Meteorological Organization (WMO) is a specialized agency of the United Nations. It is 'the UN system's authoritative voice on the state and behavior' of the earth's atmosphere and climate. WMO publishes WMO-No. 8 *Guide to Meteorological Instruments and Methods of Observation*, 2023 edition, in which a table is included on "level of performance" of pyranometers. Nowadays, WMO conforms itself to the ISO classification system.

Another useful source is the Baseline Surface Radiation Network, BSRN Operations Manual (WMO / TD No 1274, L. J. B. McArthur, April 2005).

In case there is no danger of dew and frost deposition, the SR300-D1 medium power mode (using the ventilator but not the heater) offers the most accurate measurements over short time intervals. The measurement in medium power mode is less sensitive to rapid changes of the instrument temperature (thermal shock) than that in normal power mode resulting in less noise on the irradiance reading.

## 4.5 General use for sunshine duration measurement

According to the World Meteorological Organization (WMO, 2023), sunshine duration during a given period is defined as the sum of that sub-period for which the direct solar irradiance exceeds  $120 \text{ W/m}^2$ . WMO has approved the "pyranometric method" to estimate sunshine duration from pyranometer measurements (*Guide to Meteorological Instruments and Methods of Observation*, Part I: Measurement of Meteorological Variables; WMO-No.8; 2023 edition; Chapter 8). This implies that a pyranometer may be used, in combination with appropriate software, to estimate sunshine duration. Ask for our application note.

Table 4.5.1 Standards with recommendations for instrument use in sunshine duration measurement.

### Standards for instrument use for sunshine duration

WMO-No. 8 *Guide to Meteorological Instruments and Methods of Observation*, Volume 1, Measurement of Meteorological Variables, 2023 edition, Chapter 8, measurement of sunshine duration, 8.2.2 Pyranometric Method

## 4.6 General use for albedo measurement

Albedo, also called solar reflectance, is defined as the ratio of the reflected to the global radiation. It is a dimensionless number smaller than 1. It is a property of the ground surface.

An albedometer is an instrument that measures both global and reflected solar radiation and, by calculation, the solar albedo, or solar reflectance for a particular ground surface.

An albedometer is composed of two pyranometers, both installed horizontally, the downfacing one measuring reflected solar radiation.

In the open field, the solar albedo depends on the directional distribution of incoming radiation and on surface properties at ground level. It is usually expressed as a single number, determined by taking an average over a day with solar elevation  $> 10^\circ$ . Changes of albedo are typically slow and seasonal, except when it snows. Albedos of typical surfaces range from about 4 % for fresh asphalt and 15 % for green grass to 90 % for fresh snow.

The classic application of albedometers is in meteorological energy balance studies, studying albedo variations of large areas over multiple years. With the rise in popularity of bifacial PV modules, there is an increased demand to measure the albedo at PV power plants. This is possible with pyranometers, but there are a few things to keep in mind.

A summary of Hukx's recommendations for albedo measurement:

Choice of instruments:

- Use spectrally flat pyranometers. For the reflected solar radiation measurement, it is essential to employ spectrally flat pyranometers—the reflected solar radiation has a different spectrum compared to the global solar radiation.
- Keep logistics simple—use the same instruments for POA, GHI and RI measurements. These are typically spectrally flat Class A (secondary standard) pyranometers. You can then also use the same calibration services.
- Use either 2 x single pyranometers or modular instruments consisting of 2 x pyranometer, this is easier for servicing and recalibration.

Location:

- The horizon should be as free from obstacles as possible. Ideally there should be no objects between the course of the sun and the instrument.
- The soil surface should be representative of the area under observation.

Installation height:

- WMO-No. 8 *Guide to Meteorological Instruments and Methods of Observation*, Paragraph 7.3.3.4 "installation of pyranometers for measuring reflected solar radiation" recommends a height of 1 to 2 m above the soil surface.
- If the pyranometer is too close to ground surface, it will measure in a small area only and its own shadow also becomes a source of error. If it is installed too high, you can no longer inspect and clean it. A 1.5 m installation height is a good compromise, allowing a high-accuracy measurement, as well as inspection and cleaning. This height also allows people to walk around the instrument without shading it as long as they keep their distance, and is sufficient to keep above most snow covers.

Use of a glare screen:

- A glare screen limits the full field of view of the downfacing pyranometer by  $5^\circ$  on all sides, from  $180^\circ$  to  $170^\circ$  (recommendation of BSRN operations manual, WMO / TD 1274 and ISO TR 9901). This is useful for horizontal albedo measurements—in case you do not use a sun screen, at sunrise and sunset the downfacing pyranometer may measure similar values as the upfacing pyranometer, suggesting albedo's larger than 1, which is physically not possible.

- Using a glare screen is not a requirement: Nowadays measurements suffering from glare-related errors are eliminated from the dataset by software limiting the measurement of the downfacing sensor to solar elevations  $> 5$  or  $10^\circ$ . This may be in post-processing, but also at the station level using the coordinates and time from GPS.
- When measuring reflected radiation in Plane of Array using a glare screen is not good practice—you simply miss part of the incoming irradiance.

## 4.7 General use for diffuse radiation measurement

With its outstanding zero offset specification and the fact that it is spectrally flat, SR300 D1 is also the instrument of choice for high-accuracy diffuse radiation measurement.

## 4.8 Reducing environmental impact

Hukx industrial pyranometers reduce environmental impact with respect to competing instruments, due to:

- lower power consumption during use
- robustness and reliability, reducing pyranometer failures
- the addition of standard dome protectors, mitigating the risk of damage to the pyranometer dome, reducing the need for unnecessary repairs
- a completely new packaging design: smaller, lightweight, plastic-free and fully recyclable
- if instruments need to be shipped for recalibration, two pyranometers fit in a single box, greatly reducing shipping volumes

As a user, you may reduce environmental impact by:

- nearby calibration, minimizing transport
- use instrument heating only if needed

## 4.9 Reducing total cost of ownership

Customers prefer Hukx pyranometers for their unsurpassed measurement accuracy and their lowest total cost of ownership. Total costs are mainly determined by costs of installation, on-site inspections, servicing and calibration:

- Coordinating internal and external surge protection and electrical insulation reduces the requirements for added protection devices, for example on the data bus.
- Pyranometers must be calibrated at least every 5 years. The recommended recalibration interval is 2 years. Such recalibration is considered good practice for any measuring instrument and is required by ISO, IEC and WMO standards covering PV system performance and meteorological monitoring. Extension of the calibration interval means the user is working beyond the rated operating conditions of the instrument. The accuracy of the measurement is put at risk. The cost of recalibration, however, can be high. Hukx's worldwide calibration network will help you reduce these costs. Learn more about Hukx [pyranometer calibration services](#).
- SR300-D1: relatively low demand on infrastructure: for heating SR300-D1's RVH™ (Recirculating Ventilation and Heating) technology requires less than 3 W power, compared to 10 W for traditional ventilation systems.
- Reduction of unnecessary on-site inspection by remote diagnostics.
- Reduction of unnecessary repair costs using a dome protector (see below).

# 5 Installation

This chapter describes the installation of Hukx industrial pyranometers SR300-D1, SR200-D1 and SR100-D1. Aspects to be considered include:

- finding a suitable location for performing measurements.
- mounting the instrument.
- the electrical installation of the instrument including earthing and surge protection.
- configuring the instrument communication settings.

These aspects are not independent, and the full content of this chapter should be considered when installing a pyranometer. Hukx recommends that the installation instructions in this document are followed and that the instrument is used within the rated conditions as listed in the section about rated operating conditions.

## 5.1 Site selection

A pyranometer has a field of view with a 180 ° full field of view angle. This should be taken into account when selecting a suitable location for installation of the instrument. Preferably, the field of view of the pyranometer should be unobstructed by nearby obstacles (e.g. buildings, trees, etc.).

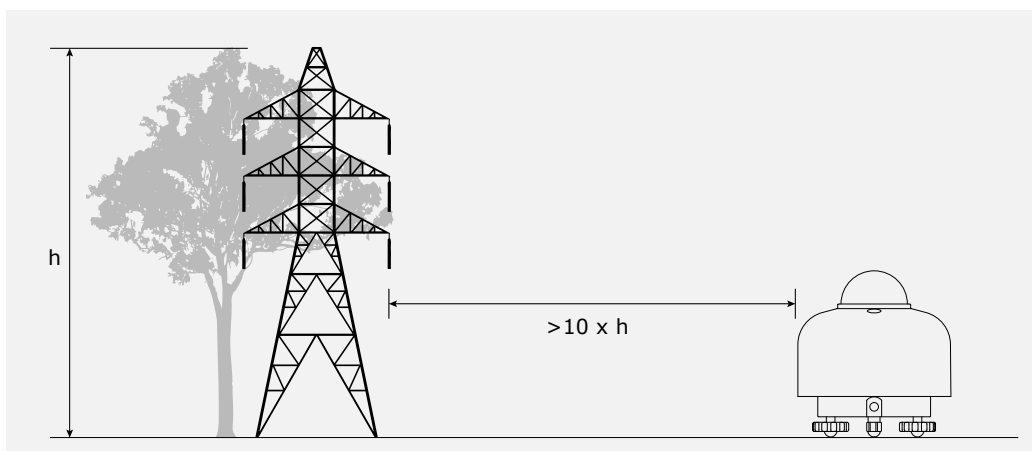

Figure 5.1.1 Preferably, the field of view of the pyranometer should be unobstructed by nearby obstacles. If obstructions are present, as a rule of thumb the pyranometer should be installed at least 10 times the height of the obstruction away from the obstruction.

For measuring Global Horizontal Irradiance (GHI), the pyranometer should be installed with the black sensor surface aligned horizontally facing upward. The bubble level and leveling feet should be used to align the instrument. When installing in a horizontal orientation, by convention, the cable exit should point to the nearest pole, so the cable exit should point north in the northern hemisphere, and south in the southern hemisphere.

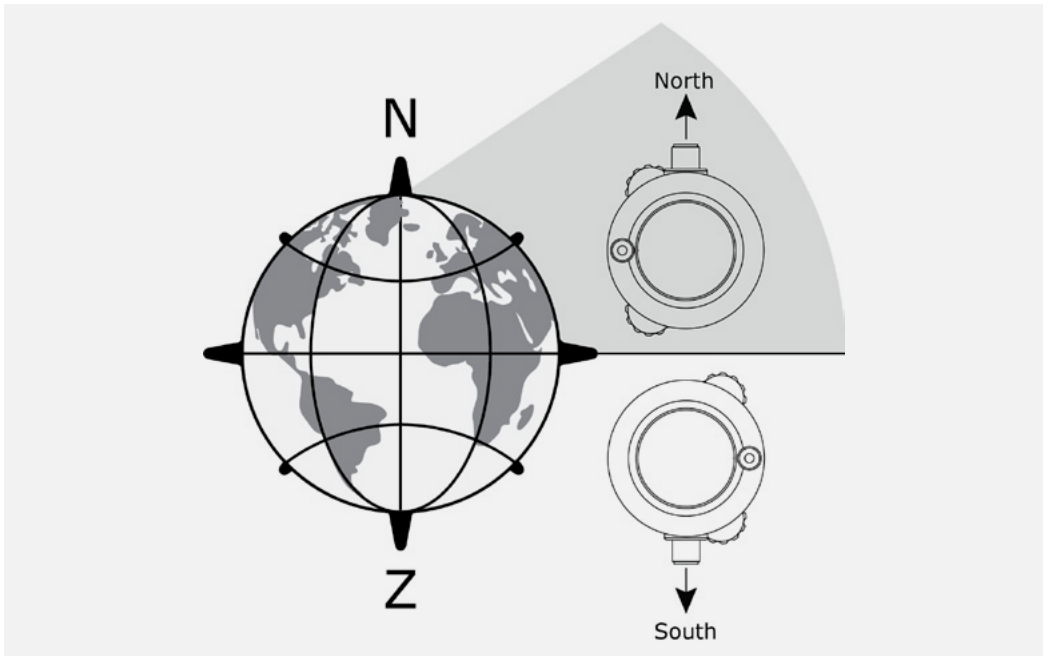

Figure 5.1.2 By convention, when installing the pyranometer in a horizontal orientation, the connector should be pointing north on the northern hemisphere and south on the southern hemisphere.

For measuring the irradiance in fixed tilt Plane of Array (POA), the pyranometer should be installed in a tilted orientation with the black sensor surface parallel to the plane of the PV module array. In this case, connectors are preferably pointed down, in order to avoid ingress of moisture. For SR300-D1 the internal digital tilt sensor may be used for long-term, remote monitoring of the instrument orientation.

When installing a pyranometer in Plane of Array (POA) on a horizontal single-axis tracker (HSAT) for PV arrays, orient the connector parallel or perpendicular to the tracker axis, depending on what is most convenient for cable management. With this cable orientation, the pyranometer can measure both the tracker tilt angle (east-west tilt) and the tilt of the tracker axis itself (north-south tilt). Note that the actual connector exit direction matters for the sign convention of the tilt sensor's tilt x and tilt y outputs. To follow the sign convention that most tracker manufacturers follow (east tilt being negative), point the connector exit north along the tracker axis or east, perpendicular to the tracker axis. See Chapter 6.3.3 for more information about the tilt sensor and the influence of connector orientation on tilt sensor outputs.

For measuring ground-reflected solar irradiance or derived quantities, such as ground albedo, a pyranometer should be installed in inverted or downward facing position. In this case, the WMO recommends an installation height above the surface between 1 and 2 m, reducing the effect of shadows and in order to obtain good spatial averaging (see also: *Guide to Instruments and Methods of Observation: Volume I: Measurement of Meteorological Variables*; WMO No.8; 2023 edition; Section 7.3.3.4; p.266). See also the chapter on albedo measurement.

## 5.2 Configuring the instrument

Hukx industrial pyranometers act as Modbus RTU server devices responding to requests from a Modbus RTU client device. The Modbus RTU protocol operates on a serial RS-485 data bus to which multiple instruments can be connected. See the section about setting up a Modbus RTU communications. Each instrument on the data bus shares the same serial communication settings, but must have a unique device address. To operate a Hukx industrial pyranometer in a SCADA network,

the instrument must be properly configured before installation. Specifically, the serial baud rate, parity bit and stop bit settings should be set to match that of all connected Modbus client devices. Additionally, a device address should be set that is unique for the RS-485 data bus that the instrument is connected to. The instrument's default settings can be found in the section about electrical specifications. Optionally, the Modbus register address configuration may be modified (see section 5.2.2).

**NOTICE**

Each device on the RS-485 network should have the same serial communication settings.

**NOTICE**

Each Modbus device on the RS-485 network should have a unique device address.

Hukx industrial pyranometers are most easily configured by connecting them to a personal computer (PC) or laptop and accessing the instrument through the Hukx Sensor Manager software. Consult the Hukx Sensor Manager manual for more details on how to use this software. Alternatively, third-party software which supports the Modbus RTU protocol can be used.

The easiest way to connect to the RS-485 interface is to use a USB-to-RS-485 converter, see the section on how to connect to a PC. On MS Windows® these converters are usually auto-configured and a virtual serial port becomes available on the system, if not, consult the USB-to-RS-485 converter documentation. This port can be used by the controlling software to communicate with the instrument.

Setting the device address and serial communication settings (BAUD rate and parity) can be done in different ways:

- By connecting the instrument to a PC and using the Hukx Sensor Manager software.
- By connecting the instrument to a PC and using another Modbus testing tool. There are links to different solutions available at [www.modbus.org](http://www.modbus.org).
- By using the available network user interface software.

For more details about programming, consult the separate "[Programming manual industrial pyranometers and diffusometers](#)" and the "register list" for your instrument model.

## 5.2.1 Adjusting irradiance sensitivity

Irradiance calibration of a digital industrial pyranometer is generally followed by adjustment of the programmed irradiance sensitivity. Updating the sensitivity is most easily done using the Hukx Sensor Manager. The instrument keeps a historic record of up to 32 updates of the calibration data, including the irradiance sensitivity, calibration dates and metadata on the calibration scale. Consult the Hukx Sensor Manager manual for detailed instructions.

## 5.2.2 Register address configuration

The Modbus register addresses of Hukx industrial pyranometers are configurable. Refer to the specification overview for the firmware versions that support this feature, as earlier firmware version may not support this. Specifically, the register addresses may be modified such that the Modbus interface of SR100-D1, SR200-D1 and SR300-D1 have a large degree of compatibility with the Modbus interface of SR15-D1, SR20-D2 and SR30-M2-D1, respectively. Refer to the [Programming manual industrial pyranometers and diffusometers](#) for details on register address mapping and to the application note [Legacy register map compatibility layer for industrial grade instruments](#) for details and limitations on the compatibility with legacy instruments.

The Modbus register addresses can be configured using the Hukx Sensor Manager. The Hukx Sensor Manager can be used to enable and disable register address mapping and to program and erase a register address map. Refer to the [Hukx Sensor Manager manual](#) for details. The Hukx Sensor Manager can connect to the instrument regardless of the register address configuration. When experiencing problems connecting to an instrument due to the register address mapping being unknown, the Hukx Sensor Manager can be used to connect to the instrument and configure the register address mapping as desired.

## 5.3 Mechanical installation of the instrument

This section describes the mounting of the instrument, the installation and removal of the sun screen, the mounting of the connector and removal of the dome protector.

### 5.3.1 Instrument mounting

Hukx industrial pyranometers can be mounted using the two M5 mounting points, or the M6 mounting point in the center, see the section about weight and dimensions for details.

Hukx offers a range of compatible mounting accessories, see sections about optional accessories and optional mounts.

When using the pyranometer in a horizontal position to measure Global Horizontal Irradiance (GHI), install the instrument on the provided leveling feet. The leveling feet allows the instrument to be installed in a horizontal position even if the mounting platform is not perfectly horizontal. The leveling feet are used in combination with the bubble level to align the instrument. By convention, when installing the instrument in a horizontal orientation the cable exit should point to the nearest pole, i.e. north on the northern hemisphere and south on the southern hemisphere.

When installing the pyranometer in Plane of Array (POA), in particular when the pyranometer tilt sensor is used for PV array tracker fault finding, the pyranometer should preferably be installed using 3 fixed feet instead of the leveling feet, see the chapter on optional accessories. Having the leveling feet in place can result in significant misalignment between the sensor surface and the PV modules. By using fixed feet the instrument can be installed parallel to its mounting platform.

When installing the instrument on a fixed tilt system in Plane of Array, keep the connector exit pointing downward to reduce the possibility of moisture ingress.

When installing the instrument in Plane of Array on a Horizontal Single-Axis Tracker (HSAT), in particular when the pyranometer tilt sensor is used for PV array tracker fault finding, orient the connector exit parallel with or perpendicular to the tracker axis, depending on what is most convenient for cable routing and strain relief, and minimization of shading on the PV modules. Make sure that the connector alignment with the tracker axis is as precise as possible to maximize the accuracy of tilt x and tilt y results. Ensure that the cable is properly secured and that sufficient slack is provided to accommodate tracker movement over the full rotation range. If the pyranometer tilt sensor is not used, the connector exit can point in any direction that is convenient.

*NOTICE*

Use fixed feet for Plane of Array (POA) installation.

*NOTICE*

When installing pyranometers on a fixed tilt system in Plane of Array (POA) the connector should preferably point downward to avoid moisture ingress.

*NOTICE*

When installing the instrument on a fixed tilt system in Plane of Array (POA) on a Horizontal Single-Axis Tracker (HSAT) the connector should preferably be oriented parallel with or perpendicular to the tracker.

Always mount the instrument either on leveling feet or fixed feet—do not mount the instrument directly onto the mounting platform. A pyranometer is sensitive to thermal shocks, i.e. rapid changes of the instrument body temperature, that may for example be caused by intermittent sunshine, rainfall or wind gusts. The use of feet thermally insulates the pyranometer body from the mounting structure, which in some cases may get very hot, mitigating the risk of thermal shocks. The use of the sun screen serves the same purpose.

Mechanical installation cannot be separated from electrical installation. Mounting the pyranometer on an electrically conducting (or insulating) platform may electrically connect (or isolate) the instrument housing from the mounting platform. The instrument mounting should not be relied on for earthing of the instrument, instead the dedicated earthing terminal must be used. Consult the following section on electrical installation design for more information.

**⚠ WARNING**

Connect the earthing terminal to earth ground to guarantee personal safety.

### 5.3.2 Leveling and alignment

Table 5.3.2.1 Recommendations for use of the tilt sensor.

application	required accuracy	reference	remarks
tilted installation	$\pm 1^\circ$	tilt sensor	Tilt measurement is sufficiently accurate.
horizontal installation	$\pm 0.1^\circ$	bubble level	Tilt measurement is not sufficiently accurate to serve as a reference for horizontal installation.

### 5.3.3 Installation and removal of the sun screen

The quick release system of the sun screen of Hukx industrial pyranometers allows for easy and secure mounting and removal of the sun screen on the instrument. It is not necessary to remove the sun screen to be able to inspect the bubble level. The sun screen allows inspection of the bubble level through a small window. To install or remove the connector to the Hukx industrial pyranometer the sun screen must be removed.

### 5.3.2 Levelings and alignment

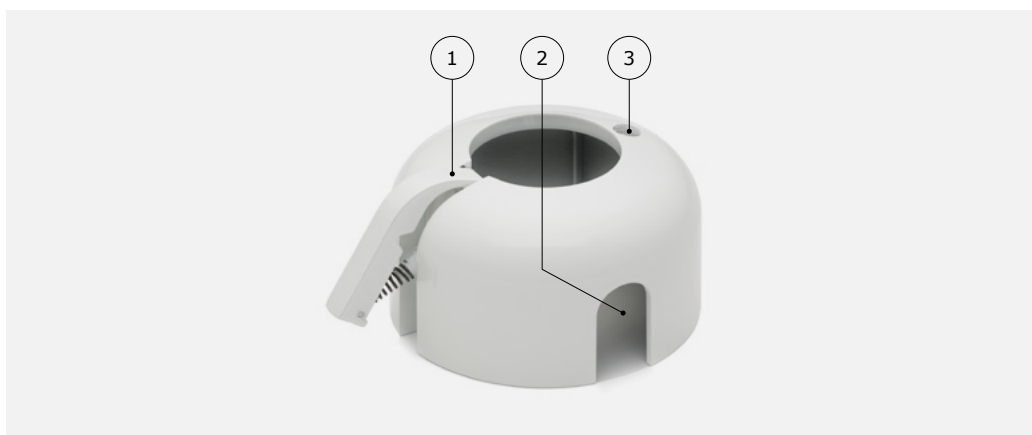

Figure 5.3.3.1 Sun screen with  
1. quick release system  
2. connector recess  
3. bubble level window

The quick release system consists of a spring-loaded lever opposite the bubble level window of the sun screen, see the Figure above. To remove the sun screen, pull out the handle from the bottom of the sun screen, then lift off the sun screen. To install the sun screen, align the connector recess on the sun screen with the connector on the pyranometer, then lower the sun screen onto the pyranometer and finally press the handle of the quick release system to lock the sun screen. Never lift the pyranometer using the sun screen as the instrument may drop out and become damaged.

**NOTICE**

Do not lift the pyranometer using the sun screen.

### 5.3.4 Connecting the instrument cable

The pyranometer is equipped with an M12-A plug connector. When connecting a cable to the instrument, ensure that the screw lock on the cable socket connector is completely tightened, as illustrated in the figure below. While tightening the screw lock, push the connector further into the instrument to fully secure the connector onto the instrument.

**NOTICE**

Failure to properly tighten the screw lock on the connector can cause poor electrical connection of conductors and cable shield and poor sealing allowing moisture to enter the connector.

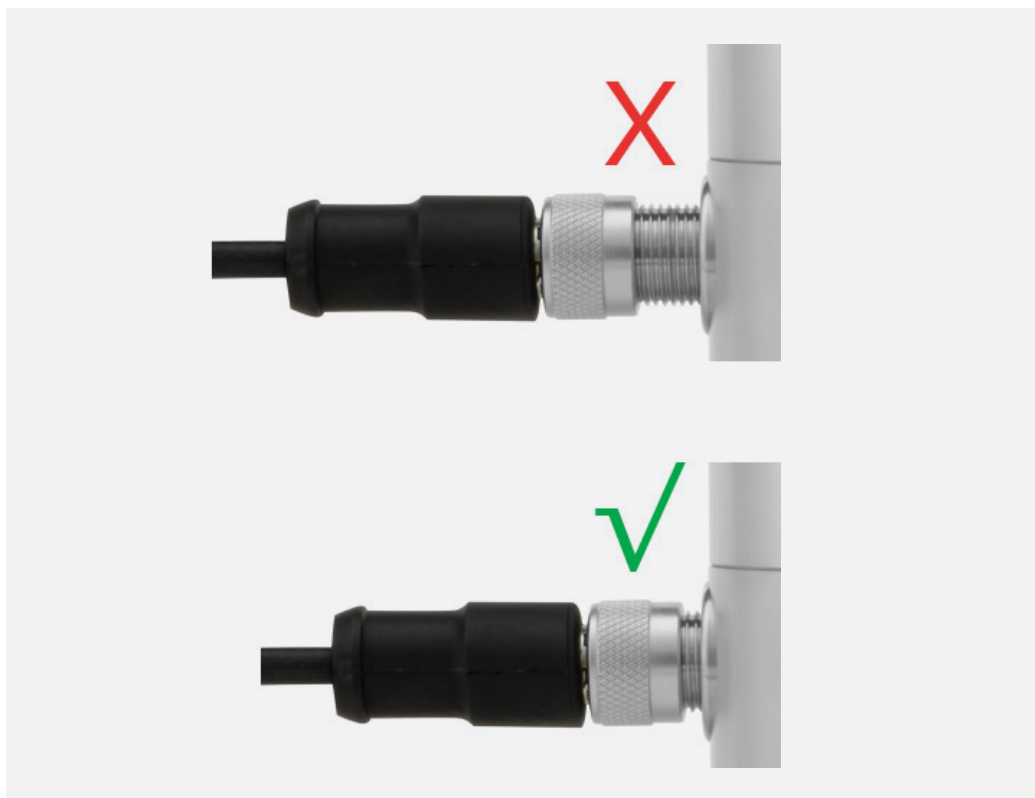

Figure 5.3.4.1 Connection of the cable connector to the chassis connector: make sure to completely tighten the screw lock. This is necessary for proper sealing against moisture and proper electrical connection of conductors and cable shield.

### 5.3.5 Installation and removal of the dome protector

Hukx industrial pyranometers are supplied with the DP01 dome protector to prevent damage during transport, installation and removal. To remove the dome protector, press on both sides of the dome protector and lift the dome protector of the instrument, as illustrated in the figure below. Remove DP01 before you start measuring.

We always recommend using DP01 when transporting, installing, and removing Hukx industrial pyranometers, such as when transporting the instrument to the installation site or when shipping the instrument to an external calibration laboratory.

#### NOTICE

Always use the DP01 dome protector when transporting, installing and removing Hukx industrial pyranometers. Failure to place the dome protector onto the instrument's dome, may unnecessarily lead to damage to the instrument optics.

Never lift the pyranometer using the dome protector as the instrument may drop out and become damaged.

#### NOTICE

Do not lift the pyranometer using the dome protector.



Figure 5.3.5.1 Hukx industrial pyranometers are supplied with a DP01 dome protector.

### 5.3.6 Optional mounts

Hukx offers a range of mounting options. See the section about optional accessories for an overview of all accessories. Consult the individual manuals of the mounting accessory for installation instructions.



Figure 5.3.6.1 Overview of Hukx mounting options.

1. TLM01
2. PMF02
3. PMF01
4. PID01
5. AMF01

#### 5.3.6.1 Leveling mount LM01

The optional leveling mount, for simplified mounting and leveling of a pyranometer on a flat surface such as a platform or bracket, is easy to use. It can be fitted to the pyranometer using the mount's spring-loaded center bolt and a 4 mm hex key or a 10 mm spanner. It can be mounted on a flat surface by inserting two M5 bolts (not included) in the designated holes.



Figure 5.3.6.1.1 Optional spring-loaded leveling mount for Hukx SR300-D1, SR200-D1 and SR100-D1.

Different ways to connect the mount to the pyranometer and lock its connection, are illustrated in the figures below. The preferred way is using a 4 mm hex key via the bottom part of the leveling mount. If the bottom part is not accessible, the connection between SR300-D1 and the mount can be made by using a 10 mm spanner. The spanner may be used as well to lock, or unlock, when the pyranometer is already fitted to the mount. In all cases, ensure the feet of the pyranometer fit into one of the small ledges of the leveling mount. Locking is in place, when the nut of the spring-loaded center bolt is turned all the way towards the bottom panel of the pyranometer.

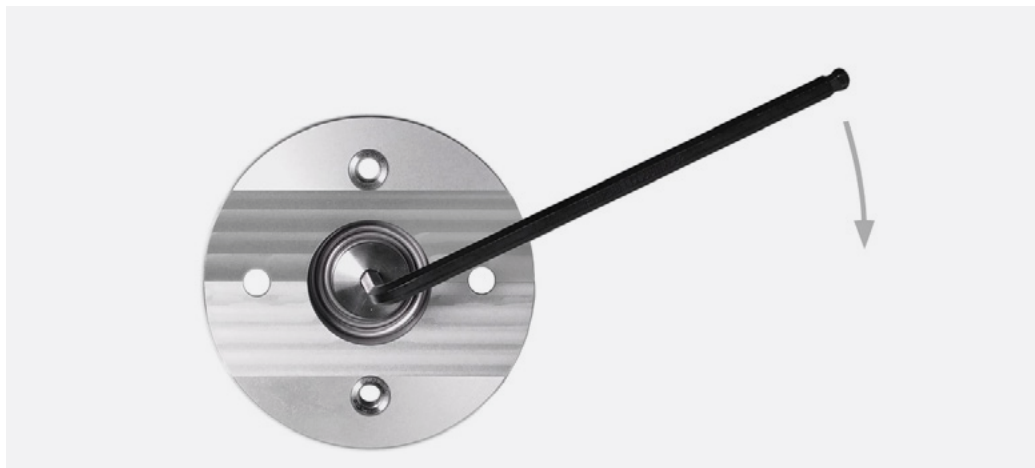

Figure 5.3.6.1.2 Bottom of LM01 leveling mount. Preferred (un) locking with 4 mm hex key.



Figure 5.3.6.1.3 LM01 leveling mount seen from above: (un) locking with a 10 mm spanner.



Figure 5.3.6.1.4 LM01 leveling mount seen from the side: (un) locking with a 10 mm spanner.

The leveling mount is spring-loaded. Once a pyranometer is connected and locked to the leveling mount, the pyranometer can be levelled by the user, using the bubble level as a reference. Leveling is done by turning the pyranometer's two adjustable leveling feet by hand. The static foot remains fixed.



Figure 5.3.6.1.5 Pyranometer locked on its optional leveling mount: by fastening (on the left) or loosening (on the right) the two adjustable feet, the pyranometer can be levelled, using the bubble level as a reference.

The static foot remains fixed. In all cases, ensure the legs of the pyranometer fit into one of the small ledges of the leveling mount. Locking is in place, when the nut is turned all the way against the bottom plate of the pyranometer.

### 5.3.6.2 Leveling mount LM01

A pyranometer may also be mounted on a tube or a mounting rod using the optional tube leveling mount.



Figure 5.3.6.2.1 Pyranometer mounted with its optional tube leveling mount on a tube.

The tube leveling mount option includes the leveling mount, described in the previous paragraph, a lower clamp for tube mounting and two sets of bolts for tube diameters 25 to 40 mm (tube not included). Installation requires a 4 mm hex key.



Figure 5.3.6.2.2 Optional tube leveling mount—installation requires a 4 mm hex key.

## 5.4 Electrical installation design

Reliable operation of Hukx industrial pyranometers is only guaranteed when the electrical installation is done according to the guidelines provided here. Especially the immunity to surges depends on the quality of the cabling, earth grounding and equipotential bonding to external protection devices. In addition, a lightning risk assessment is strongly recommended to adjust lightning protection measures to be balanced to the present risk for damage by lightning.

### 5.4.1 Lightning protection

Any outdoor installation is vulnerable to nearby and direct lightning strikes. To reduce the risk of permanent damage we advise to install lightning protection. Lightning strikes can be direct or indirect. Direct strikes can be avoided by installing lightning rods. The location and height of these rods follows from a lightning risk analysis.

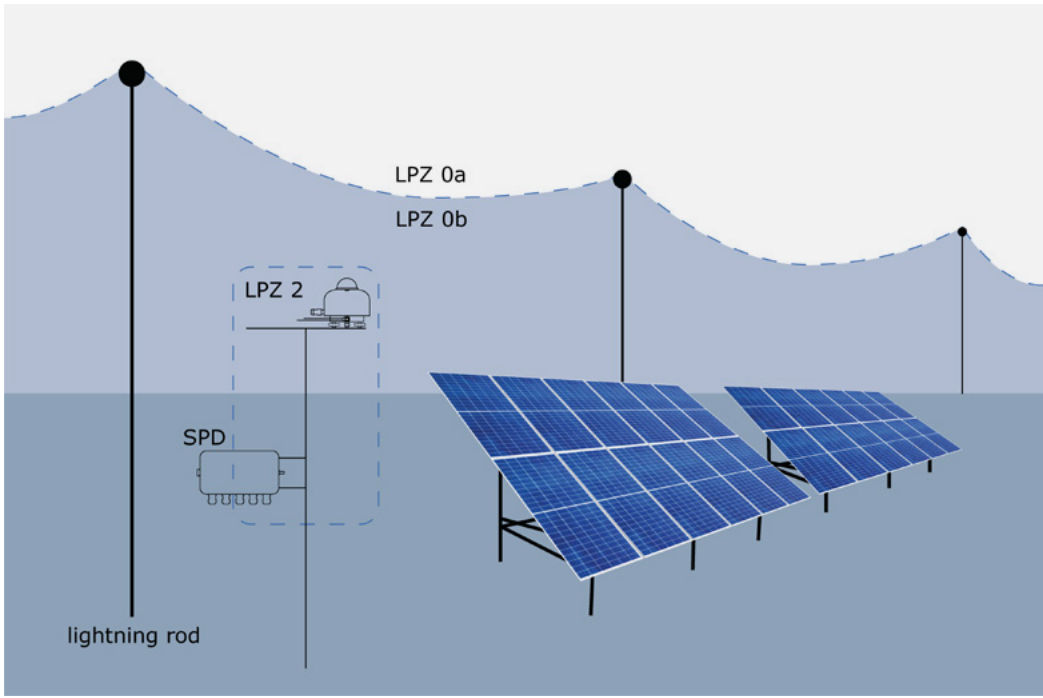

Figure 5.4.11 Hukx industrial pyranometers should be installed in LPZ2. Hukx SPD01 is a type 2 SPD which is used on the zone boundary from LPZ0b to LPZ2.

Damage from indirect lightning strikes takes place through the mounting structure and cabling attached to the pyranometer and SCADA system. To reduce the risk of damage from indirect lightning strikes, appropriate surge protection is needed. The lightning risk analysis provides guidance in selecting the correct type of SPD. In general, the Hukx industrial pyranometers should be installed in lightning protection zone 2 (LPZ2) as defined in IEC 62305-4:2010 Section 4.3. On each zone boundary, an SPD of the correct type should be installed as indicated in Figure 5.4.11. For example, the Hukx SPD01 is a type 2 SPD which is used on the zone boundary from LPZ0b to LPZ2.

### 5.4.2 Cabling and surge protection

An optional cable may be supplied with the pyranometer. This cable is used to connect the pyranometer directly to a SCADA system or via a Surge Protection Device (SPD) such as SPD01 to a SCADA system. When designing a system for outdoor use in industrial environments take note of the following points:

- EMC specifications of the pyranometer and, more specifically, surge immunity specifications depend on design of the entire electrical installation and are the responsibility of the user.
- Consider the risk of surges due to lightning strikes or high-power switching events at the installation site to decide if an SPD is needed to protect the pyranometer.
- Keep cable connecting pyranometers to a SCADA system as short as possible, longer cables are more susceptible to electrical disturbances such as electrical surges.
- SPD01 can be used to protect up to 3 instruments that are installed close together.

**NOTICE**

For instruments that are integrated into a larger system, EMC and surge immunity specifications depend on design of the entire electrical system and are the responsibility of the user.

## NOTICE

Follow the recommendations of this manual for electrical system design.  
Keep cables as short as possible and resistance to earth as low as possible.

Cabling from pyranometer to the SCADA system can be extended to an arbitrary length not exceeding the maximum length allowed for RS-485 systems. From the point of view of instrument specifications, there is no limit to the cable length. In reality the system design, environmental factors, data communication speed, required operating voltage, use of additional SPD's, etc. will determine possibilities for cable extension. In practice, 100 meters (328 ft) is an economical, safe, and reliable maximum to work with, which is why we recommend this as a maximum. When extending cables the following must be considered:

- The conductor cross-section or wire gauge (AWG) of the power wires, the corresponding electrical resistance of those wires and the resulting voltage drop. Ensure that the voltage at the location of the instrument never drops below the minimum operating voltage taking the worst-case situation with the maximum in-rush current for each device attached to the power wires.
- Noise pick-up by long signal cables may cause communication failures. To reduce this effect, use well-shielded cables with twisted wire pairs.
- Cables must be suitable for permanent outdoor use.
- Consider the use of shielded cables to improve electromagnetic immunity and reduce electromagnetic emissions.
- Consider the use of cable with twisted pairs to improve electromagnetic immunity and reduce electromagnetic emissions.
- Use of an SPD is another possibility to increase immunity, thereby allowing the use of longer cables.

## NOTICE

Adding components to the system such as surge protection devices may lead to surge immunity higher than those specified under test conditions also potentially allowing use of cables to the SCADA system longer than the recommended maximum.

Working with a pyranometer directly connected to a power supply, to reduce the risk of fire and secondary damage to the instrument or power supply, it is good practice to install a slow-blow fuse (not a fast-blow fuse) on the power supply.

In case an SPD is used, note that use of slow blow fuses may be mandatory because in case of a failure, SPD's (such as SPD01) are designed to cause an electrical short between VDC[+] and VDC[-]. This is to protect the pyranometers in case the SPD fails to perform its function.

In case multiple pyranometers are connected to one power supply, multiply the advised current rating of the fuse with the number of pyranometers attached to the power supply.

**⚠ CAUTION**

To reduce the risk of fire, install a slow-blow fuse on the power supply.

The pyranometer cable shield should be connected to earth ground on both sides to meet the EMC specifications and surge immunity as listed in the tables in section 3.4. On the pyranometer-end the cable shield is connected to the instrument body and is connected to the earth by connecting the instrument body to the earth using the earthing terminal, see next section. In cases where it is not possible to connect the cable shield at both ends, e.g. because of earth potential differences, it may be left disconnected at one end, but EMC specifications (emission and immunity) of the resulting installation may deviate from the specifications in Chapter 3.

**NOTICE**

EMC specifications (emission and immunity) are only valid when a shielded cable is used which is connected at both ends.

When pyranometers are used in non-industrial environments, for example, in indoor experiments, users may decide to require compliance with lower-than-industrial levels of surge immunity.

### 5.4.3 Earth ground

Equipotential bonding is particularly important when protecting pyranometers with an SPD. Neglecting to create a low-resistance connection between the SPD and the pyranometer makes the SPD ineffective and may result in permanent damage to the instrument. Using the cable shield for this is discouraged as this also puts the pyranometer at risk of damage due to interference in the cable shield.

**⚠ CAUTION**

The absence of a low-resistance connection (equipotential bond) between a pyranometer and SPD may reduce the effectiveness of surge protection.

Hukx industrial pyranometers and the optional SPD01 both feature an earthing terminal indicated by an earth ground symbol ( $\perp$ ), see the Figure below. Both earthing terminals should be connected to protective earth and equipotential bonding should be realized between the earthing terminals of the pyranometers and SPD01. Equipotential bonding is required to avoid any significant current flow through the instrument cable shield which may cause the instruments to function unreliably (loss of data) or, eventually, to cause damage. Hukx industrial pyranometers and SPD01 should be connected to the same earth potential and the resistance between these two connections points should be minimized, ideally the resistance should not exceed 1Ω. Proper earthing can only be realized through the earthing terminal. The pyranometer feet or any of the mounting screw holes should not be relied on for earthing of the instrument body.



Figure 5.4.31 Hukx industrial pyranometers earthing terminal.

Earthing of exposed metal parts of an electrical installation is required by many local safety regulations to ensure that the installation is safe to work on for supporting personnel. See "Electrical specifications", section 3.4 for earthing terminal specifications.

**⚠ WARNING**

Connect the earthing terminal to earth ground to guarantee personal safety.

When a Hukx industrial pyranometer is directly connected to a SCADA system, the earthing terminal of the pyranometer should be connected to earth as well as the earth ground of the SCADA system to realize equipotential bonding.

#### 5.4.4 Electrical isolation

Hukx industrial pyranometers may be safely installed directly onto a PV array. The electrical potential of the array support structure may be affected by for example fault currents and lightning strokes. Therefore special care should be taken to protect devices from potential differences that may be present in different parts of the entire PV system. When installing industrial pyranometers on the PV array structure they should preferably be electrically isolated from the PV array structure. This can be realized using the Pyranometer Isolation Disk (PID01), see the list of accessories in Section 3.6. Earthing of the pyranometer body must then be realized through the earthing terminal which should be connected to protective earth and to the earthing terminal of an SPD when present. This allows pyranometer installation onto the PV array without detailed knowledge of the PV plant grounding structure.



Figure 5.4.4.1 SR300-D1 with PID01 to be used for on-array installation.

### 5.4.5 RS-485 network

Hukx industrial pyranometers are used in a two-wire (half-duplex) RS-485 network. In such a network the pyranometer acts as a server device and responds to data requests from the client device. An RS-485 network (or bus), consists of a wire pair for data transmission and a signal ground wire. The three channels are:

- RS-485 data[+], B' or B (non-inverted lines)
- RS-485 data[-], A' or A (inverted line)
- RS-485 signal ground

RS-485 uses differential signaling for data transmission. This means that the logic states are encoded in the electrical potential difference between the data[+] and data[-] lines, whereas on a single-ended interface it would be encoded in the potential of the data line with respect to the signal ground. For RS-485, the signal ground is required to provide a reference for the common mode reference potential, common to the data[+] and data[-] lines. When designed and installed correctly, RS-485 provides a robust reliable communication channel in electrically noisy environments.

The RS-485 interface of the industrial pyranometers is internally isolated from the internal electronics as well as from the instrument body, see the Figure below. Both isolation barriers are rated at 1.5 kV.

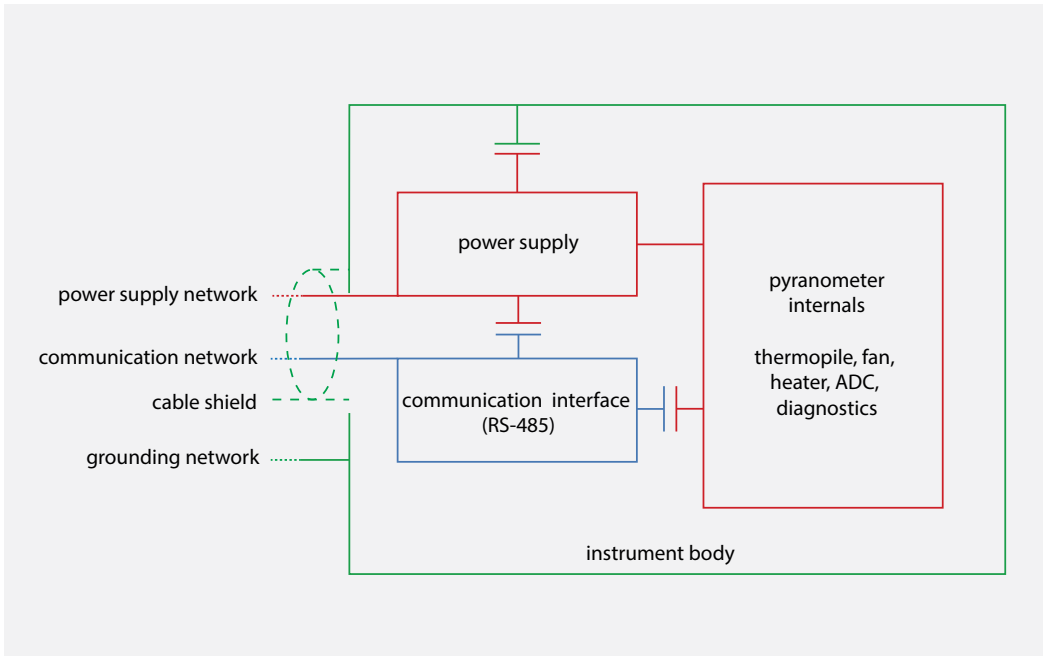

Figure 5.4.5.1 Schematic representation of industrial pyranometers indicating the electrical connections and the different isolation barriers.

An example of the topology of an RS-485 2-wire network is shown in the below Figure. The network has a linear setup with side branches, called stub lines, to the nodes and line termination resistors at each end. Each node in the network is protected by a surge protection device such as SPD01.

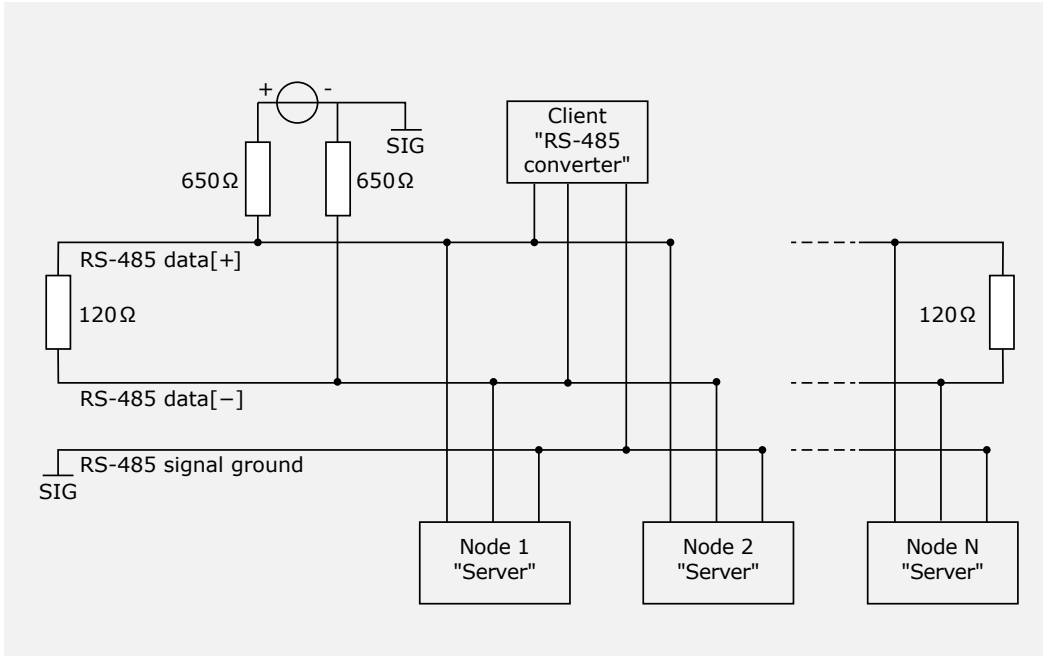

Figure 5.4.5.2 Typical topology of a 2-wire (half-duplex) RS-485 network. This figure does not show the power supply or any isolators that may be required.

Line termination must be installed at both ends of the bus between the data[+] and data[-] lines. According to the RS-485 standard (EIA-485), termination resistors have a value of 120 Ω and no more and no less than two-line termination resistors should be installed in a single network, see "Modbus over serial line specification and implementation guide v1.02", section 3.4.5. Failure to install line termination resistors leads to signal reflections which could compromise signal integrity, especially for large networks. Placing more than two line termination resistors causes excessive loads on the RS 485 bus which may compromise signal integrity and may lead to damage to equipment.

### NOTICE

Line termination is required at both ends of the bus between the data [+] and data[-] lines. Two, and no more and no less, than two termination resistors should be placed.

A so-called fail-safe biasing circuit or line polarization circuit is recommended to keep the data lines in a well-defined state when not being driven by any transmitter, see "Modbus over serial line specification and implementation guide v1.02", section 3.4.6. To do so, pull-up and pull-down resistors have to be installed on the data[+] and data[-] lines, respectively, as shown in figure 5.4.5.2. Typical values for both resistors are in the range of 650 to 850  $\Omega$ . On the data[+] line this resistor is connected to a +5 VDC supply which is referenced to the signal ground and on the data[-] line to the signal ground. This will keep the data lines in a well-defined state when none of the connected devices is controlling the bus. In the absence of a fail-safe biasing circuit devices (receivers) are more susceptible to external noise and may cause Modbus communication with the instrument to fail.

### NOTICE

An RS-485 fail-safe biasing (line polarization) circuit is recommended.

The maximum allowable stub length depends on the data rate, but in general it should be kept as short as possible to avoid signal reflection in these un-terminated line elements. The lower the data rate of the serial communication, the longer any stub lines may be without causing problems, see "Modbus over serial line specification and implementation guide v1.02", section 3.4.3. Never use stub lines longer than 20 meters.

### NOTICE

Do not use stub lines (derivations) longer than 20 m.

## 5.5 Electrical connections

This section provides an overview of the electrical connections of Hukx industrial pyranometers, when using the factory-supplied cable.

### 5.5.1 Wiring and connections

To use a Hukx industrial pyranometer, the instrument must be connected to a power supply and an RS-485 network via the M12-A connector. Table 5.5.1 shows the electrical connections with the insulation colors used in the cable, which is an optional part of the delivery.

Table 5.5.1 Cable and connector connections of Hukx industrial pyranometers. Pin numbering as indicated in the figure below.

PIN*	Conductor insulation color	Function
1	brown	VDC [+]
4	black	VDC [-]
3	blue	RS-485 signal ground
2	white	RS-485 data [+], B' or B
5	grey	RS-485 data [-], A' or A
-	yellow	cable shield/instrument body

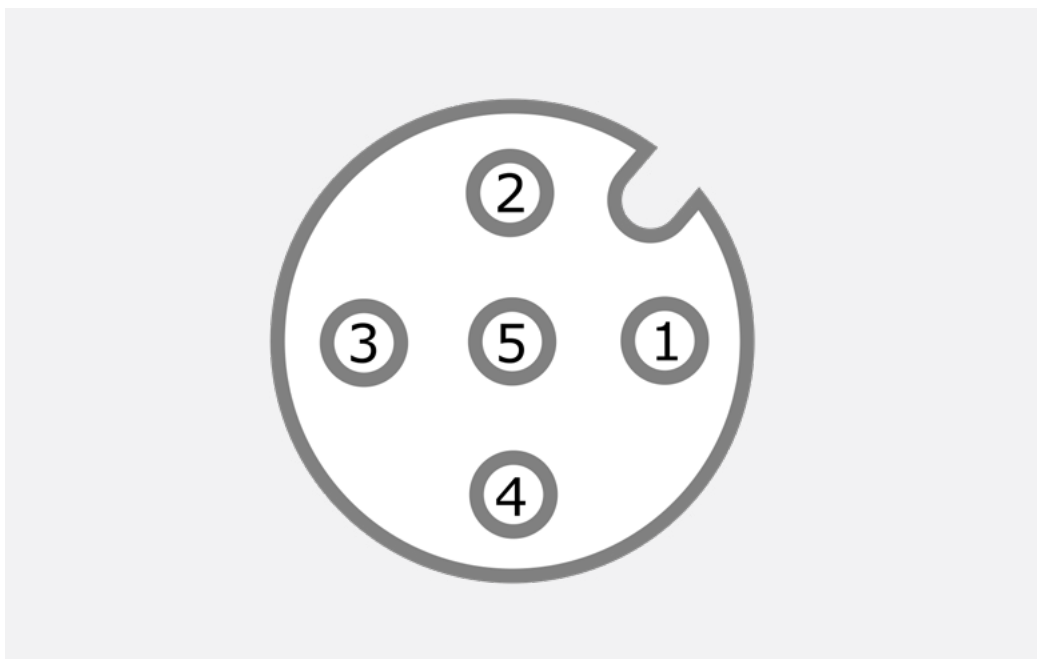

Figure 5.5.1 Schematic of the M12-A connector layout of Hukx industrial pyranometers, indicating the PIN numbers.

### 5.5.2 Earth connection

For safe and reliable use of industrial pyranometers, the earthing terminal is used to connect the instrument body to earth ground, see Section 5.4.3. The conductive instrument body is in turn connected to the connector body which provides an earth connection for the cable shield.

### 5.5.3 Connection to a PC

Configuration of Hukx pyranometers is most easily done with the instruments connected to a PC and using the Hukx Sensor Manager software. This software provides a user-friendly way to connect to the instrument and to adjust the communication settings, even without knowledge of the current configuration settings using the dedicated auto-connect feature. Alternatively, another Modbus RTU communication tool can be used. For more details about programming, consult the separate "[Programming manual industrial pyranometers and diffusometers](#)" and the "register list" for your instrument model.

To connect to a PC many RS-485 converters are available. Two recommended and tested RS-485 converter models are:

- Advantech, Adam-4561, 1-port Isolated USB to RS-232/422/485 Converter
- Moxa, Uport 1150I, 1-port RS-232/422/485 USB-to-serial converters with optical isolation protection

#### NOTICE

When using the popular RS-485 converter solutions manufactured by the FTDI company, e.g. model USB-RS485-WE-1800-BT using the FT232R chipset, use so-called fail-safe biasing resistors as the idle state of these converters is undefined and is likely to cause communication problems.

In particular, when using an isolated converter the signal ground must be connected to the VDC[-] wire to get a reliably functioning connection to the PC.

## 5.6 Setting up Modbus RTU communication

Hukx industrial pyranometers function as Modbus RTU servers. The instruments must be used in conjunction with a client device, such as a PC or data logger. The server device responds to requests sent by the client device.

This section provides a brief overview of how to retrieve the most important Modbus registers: the temperature compensated irradiance and the instrument temperature through the Modbus interface. For an in-depth description of the Modbus interface of the Hukx industrial pyranometers, including an overview of supported function codes, data types and example code, consult the "[Programming manual industrial pyranometers and diffusometers](#)". There is a register list for every instrument model. These can be downloaded via [www.hukx.com/downloads](http://www.hukx.com/downloads). For general information regarding the Modbus protocol, consult the "Modbus Application Protocol Specification" and the "Modbus over Serial Line Specification and Implementation Guide", available from Modbus Organization.

### 5.6.1 Reading the irradiance

The temperature compensated irradiance can be read using Modbus function codes 0x03 (read holding register) or 0x04 (read input register). In addition to reading the temperature compensated irradiance it is recommended to read at least the "high internal humidity indicator" at regular intervals.

## Modbus registers

register address (HEX)	parameter	description	data type
0x0200	temperature compensated irradiance	the temperature compensated irradiance in W/m <sup>2</sup>	float
0x0685	internal high humidity indicator	alert for high internal humidity	bool

### 5.7 Programming, register structure

For more details about programming, consult the separate “[Programming manual industrial pyranometers and diffusometers](#)” and the “register list” for your instrument model.

The version of these documents corresponding to the firmware version of the instrument can be downloaded via [www.hukx.com/downloads](http://www.hukx.com/downloads).

# 6 Instrument diagnostics

Hukx industrial grade pyranometers provide various possibilities to perform instrument diagnostics. Read the following section to see which diagnostic features are supported by the different instrument models.

For SR300-D1 the power and communication status LED provides a visual check of the instrument status. This on-site diagnostic feature can be convenient during installation or while inspecting the instrument before use or during servicing.

Remote diagnostic sensors inside the instruments allow early detection of potential problems and, if followed by appropriate action, can help to prevent loss of data or damage to the instrument. Most remote diagnostic signals are a combination of sensor readings and alerts showing whether the value is within an acceptable range or not. It is recommended to read and store the alert indicators at regular intervals. Storing the corresponding sensor signals is also required for a more detailed diagnosis. Whenever an indicator flag is set by the instrument, setting of an alert, it is recommended to collect and review the underlying sensor data of the past year. Historic sensor data helps experts in taking appropriate actions to solve the problem.

A detailed description of how to read the Modbus registers for instrument diagnostics can be found in the separate "[Programming manual industrial pyranometers and diffusometers](#)" and in the "register list" for your instrument model. The documentation needed for the instrument firmware version can be downloaded via [www.hukx.com/downloads](http://www.hukx.com/downloads). Be aware that depending on the firmware version of the instrument, not all features may be present or behavior of features may have undergone changes.

## NOTICE

Verify that the version of the instrument firmware corresponds to the version described by the documentation as addition of features and changes to features (expansion) may be included in as part of instrument firmware updates

## 6.1 Instrument diagnostics for different pyranometer models

Table 6.1 Copy of the table in the specification overview.

Instrument diagnostics	SR300-D1	SR200-D1	SR100-D1
<b>on-site diagnostics</b>			
power and communication status LED	•	-	-
<b>remote diagnostics alerts</b>			
high internal humidity	•	•	•
instrument leakage	•	-	-
change of tilt	•	-	-
change of rotation	•	-	-
heating and ventilation malfunction	•	-	-
<b>remote diagnostics measurements</b>			
instrument body temperature	•	•	•
internal humidity	•	•	•
instrument tilt	•	-	-
instrument rotation	•	-	-
instrument tilt x*	•	-	-
instrument tilt y*	•	-	-
internal pressure	•	-	-
heater current	•	-	-
ventilator current	•	-	-
ventilator speed	•	-	-
* firmware version 1.9.0 and higher			

## 6.2 On-site diagnostics: status LED (SR300-D1 only)

The power and communication status LED can be used as a visual check by local operators to verify that the instrument is properly connected to power and communicates with a Modbus RTU client.

During startup, typically less than 10 s after connection of power, the status LED will be [ON] continuously. After startup, in measurement mode, the behavior of the status LED depends on the LED mode setting. This can be set in the LED mode register. The LED has the following modes:

- OFF: the LED will never be [ON].
- ON: the LED will be [ON] continuously.
- AUTO (default): every 15 seconds the LED will [BLINK]:
  - 1 x [BLINK]—the instrument is powered,
  - 2 x [BLINK]—the instrument is powered and has detected communication on the RS-485 bus in the last 15 seconds, but the communication is either not a valid Modbus request or it is not directed at the instrument.
  - 3 x [BLINK]—the instrument is powered and has detected Modbus communication on the RS-485 bus directed at the instrument in the last 15 seconds.
- IDENTIFY: the LED will be [ON] for 15 seconds and then switch back to the previous state (OFF, ON or AUTO), this can be useful to identify the instrument whenever multiple instruments of the same model are present.

The AUTO mode is used when debugging instrument connections. The blinking patterns are illustrated in Figure 6.11. When the LED does not blink, the instrument is not powered. In that case, check the power supply and power wiring.

Whenever the LED blinks once, the instrument detects power but no communication. Either there is a problem with the RS-485 wiring or the Modbus client device (PC or data logger) is not sending any Modbus requests. In that case, inspect the RS-485 bus wiring and the client device programming.

Whenever the LED blinks twice, the device detects data communication on the RS-485 bus, but either the data does not constitute a valid Modbus request or the Modbus request is not targeting the instrument. In this case, inspect the client programming, starting with the device address to which it is sending data.

When the LED blinks three times the instrument is responding to Modbus requests, which is normally the desired behavior.

Whenever the LED blinks five times in rapid succession, the instrument is in maintenance mode. This mode is intended for factory use only. To exit maintenance mode, reboot the instrument by disconnecting the power.

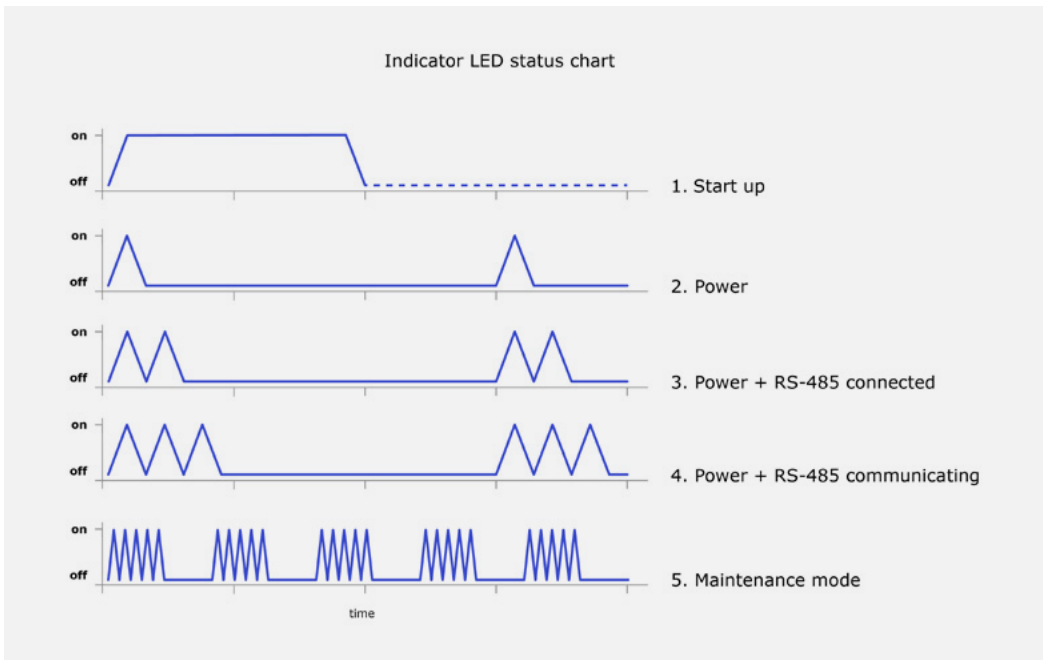

Figure 6.2.1 Power and communication status LED behavior.

### 6.3 Remote diagnostics

#### 6.3.1 Instrument temperature

Measurands for diagnostics	
measurand	instrument body temperature
instrument body temperature measurement accuracy	± 0.1 °C

Check the instrument temperature against the dewpoint or ambient air temperature. During daytime, the instrument temperature is normally higher than ambient temperature. Solar radiation will heat up the instrument potentially by 10 °C. For SR300-D1 the internal heating may add several degrees to that.

At night, the instrument temperature is normally lower than ambient air temperature. Infrared radiation loss from the sky causes the instrument to cool, potentially to temperatures below dewpoint. For SR300-D1 the internal heating may keep the instrument permanently above dewpoint.

The instrument temperature should preferably be higher than the ambient temperature and dewpoint. Whenever the instrument body temperature is below the dewpoint, water condensation may form on the outer surface of the pyranometer, including the outer dome, which can affect the irradiance measurement.

## 6.3.2 Internal relative humidity

### Measurands for diagnostics

<b>alert</b>	high internal humidity flag
<b>behavior</b>	triggers when internal humidity exceeds 40 %
<b>measurand</b>	sensor internal relative humidity
<b>relative humidity sensor accuracy</b>	$\pm 3 \% \text{ RH}^*$

\* Below 0 °C the humidity sensor output will always be 0 % RH.

Instruments are manufactured and supplied with an internal bag of desiccant. For new instruments, the internal relative humidity will be below 20 % RH at room temperature. Over time, by diffusion through the instrument sealing, the internal relative humidity levels will increase. When a pyranometer accumulates too much moisture, water condensation inside the instrument may cause incorrect measurements and will eventually damage the instrument's electronics. It is therefore recommended to monitor the internal relative humidity and the corresponding alert via the high internal humidity indicator register at regular intervals. When the internal relative humidity exceeds the threshold of the high internal humidity, an alert is raised and an indicator flag is set. The threshold is set to the recommended default of 40 % RH. Above this range, the instrument will not function reliably anymore, see the table on "rated operating conditions" in the specification chapter.

In case the 40 % RH limit is attained, review the internal relative humidity and temperature data of the past years. For SR300-D1, also review the instrument leakage indicator flag and the pressure and temperature data.

If humidity changes show a steady gradient over the years, less than 10 % average change of RH per year at comparable temperatures, this is a sign that the instrument is not leaking. For SR300-D1 leakage may also be detected by analyzing temperature and pressure data. As long as we expect—based on extrapolated data—to remain below 60 % RH action is not urgent. Servicing may be postponed, for example to the next calibration. In RH is consistently higher than 60 % we recommend immediate action.

In case of doubt, contact the manufacturer to discuss the data and the appropriate maintenance actions.

In case of condensation of droplets inside the instrument, contact the manufacturer. At the factory it is possible to replace the desiccant, and it may be possible to repair the instrument in case of leaks.

### 6.3.3 Instrument tilt, rotation, tilt x\* and tilt y\* (SR300-D1 only)

#### Measurands for diagnostics

<b>alert</b>	change of tilt flag
behavior	disabled, must be configured by user before use
<b>alert</b>	change of rotation flag
behavior	disabled, must be configured by user before use
<b>alert</b>	change of tilt x flag*
behavior	disabled, must be configured by user before use
<b>alert</b>	change of tilt y flag*
behavior	disabled, must be configured by user before use

\* for firmware version 1.9.0 and above

To allow remote monitoring of the instrument orientation and to assist in the tilted installation of the instrument, the SR300-D1 is equipped with a tilt sensor. The onboard accelerometer measures the gravitational acceleration along three orthogonal instrument axes and calculates the corresponding (zenith) tilt, rotation, and for firmware version 1.9.0 and above, tilt x and tilt y angles of the pyranometer. Please consult paragraph 3.8 for the specifications of these measurands.

It is possible to use three different representations for the instrument's orientation relative to gravity: the x-, y-, and z-components from the accelerometer, the tilt and rotation outputs, and the tilt x and tilt y outputs. Use the representation that works best and is easiest to interpret for your specific application. When using the x-, y-, and z-component, make sure to use the (temperature) compensated component values. For other outputs the signals are always temperature compensated.

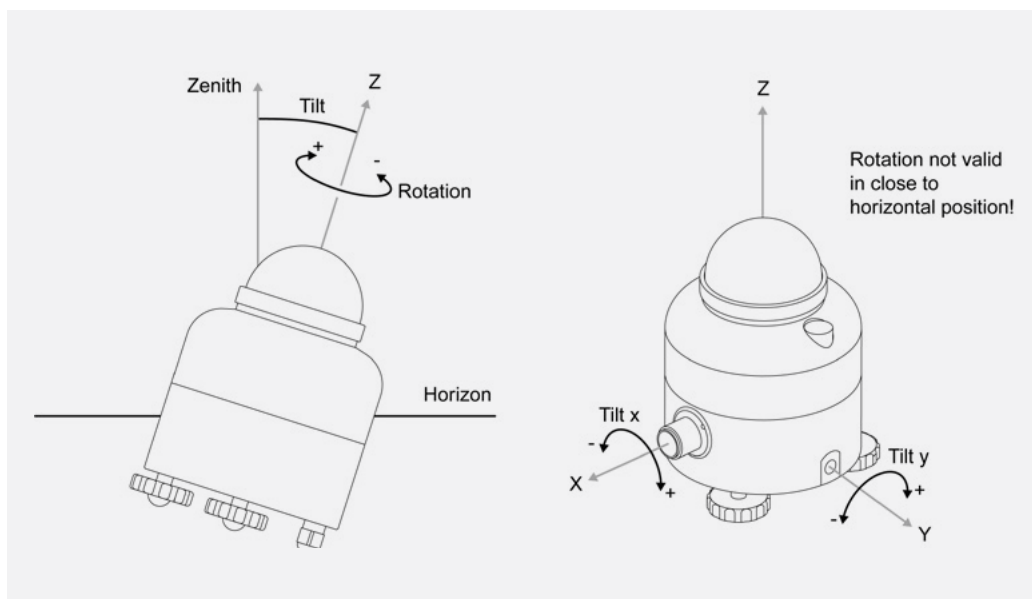

Figure 6.3.3.1 Illustration of the accelerometer x-, y- and z-components and the tilt, rotation, tilt x and tilt y angles. In the left image, the rotation is zero degrees, and the tilt and tilt y are both a positive angle. In the right image, the tilt, tilt x and tilt y are zero degrees, and the rotation is not valid, because the sensor is in a horizontal position.

When mounting the instrument with a fixed orientation, the x-, y-, and z- components, tilt and rotation, or tilt x and tilt y measurements can be used to monitor slow, long-term changes as well as incidents that cause the instrument to move. Additionally, alerts are triggered when predefined limits for tilt, rotation, tilt x, or tilt y are exceeded. These thresholds can be configured by the user using the Hukx Sensor Manager. By default, all alerts are inactive and must be explicitly enabled during configuration. For a detailed description of available alerts and configuration instructions, refer to Appendix 8.11.

Due to inherent limitations of the accelerometer, rotation, tilt x, or tilt y become poorly defined when their respective instrument axes (Z, X, or Y) are aligned with the zenith. In these orientations, the calculated values fall outside their valid operating range and should not be used. For rotation, firmware version 1.6.0 and later holds the reported value at the last valid measurement when the instrument operates outside the valid range, until the sensor returns to a valid orientation. This prevents unstable or ambiguous readings. Tilt x and y, which are available starting with firmware version 1.9.0, apply the same behavior from their introduction: when operating outside their valid range, the output remains fixed at the last valid value.

Most horizontal single-axis tracker (HSAT) systems report a negative tracker angle when the PV array is tilted towards the east, zero at solar noon, and a positive angle when the PV array is tilted towards the west. In this case, to allow for direct comparison of the tracker angle with tilt x or tilt y, the connector exit should point to the north or east respectively. This simplifies interpretation of tilt data and improves monitoring of tracker performance and structural behavior. See the table below for more information about the correspondence of tilt x and tilt y to cardinal directions as a function of connector exit direction. In this table, pluses and minuses indicate whether the tilt x or tilt y angles are positive or negative. For example, when the connector is pointing south and the pyranometer is tilted towards the east, the tilt x angle is positive.

### Directionality of tilt x and tilt y

connector direction	tilt x angle	tilt y angle
north	east (-) to west (+) tilt	north (-) to south (+) tilt
east	north (+) to south (-) tilt	east (-) to west (+) tilt
south	east (+) to west (-) tilt	north (+) to south (-) tilt
west	north (-) to south (+) tilt	east (+) to west (-) tilt

Note that when trackers move, the accelerometer's measurement is not within rated operating conditions and no longer reliable.

## NOTICE

For pyranometers mounted on moving objects such as solar trackers: tilt sensor measurements will not be accurate while the accelerometer axes move relative to gravity. Disable or ignore the output in case this produces significant errors.

Consult the "[Programming manual industrial pyranometers and diffusometers](#)" and the instrument "register list" for more details.

### 6.3.4 Alert for instrument leakage (SR300-D1 only)

#### Measurands for diagnostics

<b>alert</b>	instrument leakage indicator flag
behavior	triggers when pressure to temperature ratio deviates from a reference value
<b>measurand</b>	sensor internal pressure
pressure sensor absolute accuracy	$\pm 1$ mbar

When the instrument is not airtight, the humidity levels inside the instrument may increase. Water condensation on the inside of the instrument may lead to incorrect measurements and will eventually damage the instrument's electronics. The leak detection may help to detect leaks early on.

Leak detection is based on the internal pressure and instrument temperature. When a leak is detected, the leak indicator flag is set. It is recommended to read and store the leak detection indicator, temperature and internal pressure registers at regular intervals.

A reference value for the leak indicator is set at the factory, however, the reference value should be updated upon installation of the instrument. Ideally the leak detection is only sensitive to leaks, however, in practice over longer time periods the leak detection may also be susceptible to seasonal effects and drift. The reference value should therefore be updated at regular intervals (see chapter 7 maintenance). Note that when the instrument is opened the reference value for the indicator needs to be reset. The reference value for the leak indicator can be set by writing the value to the leak detection reference register. This can for example be done using the Hukx Sensor Manager. The user may also adjust the maximum allowed deviation of the pressure-and-temperature-ratio. The procedure for resetting of the leak indicator is described in the Hukx Sensor Manager manual.

When the leak indicator flag is set, collect and carefully review the temperature and pressure data as well as the relative humidity data from the past year and contact the manufacturer to discuss the data and appropriate maintenance actions. Changes in the leak detection value (pressure-to-temperature ratio) may occur as a sudden jump, e.g. in case of a broken outer dome, or gradual resulting from a small leak, e.g. near the connector. At the factory it is possible to replace O-ring sealings and it may be possible to repair the instruments in case of other leaks.

### 6.3.5 Ventilation and heating (SR300-D1 only)

Measurands for diagnostics	
<b>register</b>	RVH™ mode register
<b>measurand</b>	heater current (indicative only)
<b>measurand</b>	ventilator current
<b>measurand</b>	ventilator speed in RPM

For instruments equipped with internal ventilation and heating the Recirculating Ventilation and Heating (RVH™) mode register is used to set the instrument to one of three modes:

- Normal power mode (dew and frost mitigation mode): in this mode the instrument is heated and ventilated for optimal dew and frost mitigation. Ventilation also reduces zero offsets.
- Medium power mode (high accuracy mode): in this mode the instrument is unheated and only ventilated. In situations where dew and frost are not an issue, this leads to the highest measurement accuracy and lowest possible instrument offsets. In some cases ventilation alone may also be sufficient to prevent dew and frost formation.
- Low power mode (power saving mode): in this mode the instrument is not heated and not ventilated to minimize power consumption.

For instruments equipped with ventilation as well as heating it is strongly recommended to use the RVH™ mode register (and not the heater state register) to control the heater. This makes it impossible to accidentally set an invalid heating mode.

The RVH™ mode registers can also be read to determine the status of the internal ventilation and heating. It is recommended to read the RVH™ mode register at regular intervals. In addition to the states mentioned above the RVH™ mode register may be in one of the following states:

- Invalid mode: in this mode the instrument is heated, but not ventilated. Use of this mode is discouraged because heating without ventilation can cause serious irradiance measurement offsets. Use only one of the valid modes.
- Error: whenever the RVH™ mode register is set to an error value, there is a problem with either the heater or the ventilator. At the moment this error message is generated, heater and ventilator are automatically switched off.

## NOTICE

If the heater is [ON] the ventilator should be [ON] as well.  
Read out the RVH™ mode register as well as heater current, ventilator current and ventilator speed.

Whenever an error occurs, it is recommended to reboot the instrument by disconnecting it from power and connecting again. If this does not resolve the problem, the individual ventilator speed, ventilator current and heater current registers can be used to further investigate the problem. Contact the manufacturer and review the data to discuss the appropriate action.

### 6.3.6 Internal heating (SR300-D1 only)

#### Measurands for diagnostics

<b>alert</b>	heater undercurrent flag
behavior	triggers when heater current drops below 200 mA
<b>alert</b>	heater overcurrent flag
behavior	triggers when heater current exceeds 500 mA
<b>measurand</b>	heater state register
<b>measurand</b>	heater current (indicative only)
<b>measurand</b>	heater duty cycle

The heater state register can be used to switch the internal heater on or off while the heater duty cycle register can be used to adjust the heater power in steps of 10 % with a minimum setting of 10 %. When using internal heating, internal ventilation should be used as well. In addition, the heater state register can also be used to obtain the current status of the heater (including any error conditions).

When the heater is [ON], a heater current register allows the user to read the heater's (peak) electrical current. The heater current measurement is an indicative, unverified measurement. Using the heater current reading, an estimation of the heater power can be made. Because the voltage across the heating element is 5.0 Volt, the heater power is given by:

$$P_{\text{heater}} [W] = 5.0 [V] \times \text{"heater current"} [A] \times \text{"heater duty cycle"} [\%] / 100 [\%]$$

Note that even though the power delivered by the heater is the largest contributor, dissipation by the ventilator and the electronic circuitry also contributes to the heating of the instrument. Therefore the overall heat generation will always be larger than just that of the heater.

### 6.3.7 Internal ventilation (SR300-D1 only)

#### Measurands for diagnostics

<b>alert</b>	ventilator undercurrent flag
behavior	triggers when fan current drops below 30 mA
<b>alert</b>	ventilator overcurrent flag
behavior	triggers when fan current exceeds 140 mA
<b>measurand</b>	fan state register
<b>measurand</b>	ventilator current
<b>measurand</b>	ventilator speed in RPM

For instruments equipped with ventilation as well as heating, preferably the RVH™ mode register instead of the fan state register is used to control the internal ventilation.

The fan state register can be used to switch the internal ventilation [ON] or [OFF]. In addition, it can be used to obtain the current status of the internal ventilation (including any error conditions). We recommend to monitor the fan state register at regular intervals.

Apart from the fan state register, the ventilator current and ventilator speed registers can be read.

The ventilator's rotation speed can vary significantly with temperature. This variation will also be reflected in the ventilator current. Apart from this, the ventilator current measurement is an unverified measurement. For these reasons, the ventilator current reading should only be used as a binary [ON]/[OFF] indicator, solely to determine the actual ventilator state independently.

The fan speed gives the actual rotation frequency of the fan in RPM (Revolutions per Minute), irrespective of whether it is switched on or off. The nominal ventilator speed is 7400 RPM at 20 °C. Depending on operating conditions the speed may vary. Especially at temperatures below -10 °C ventilator speed may be significantly lower. When the speed consistently falls below 2000 RPM, maintenance is required, and replacement of the ventilator may be needed. See chapter 7 for details on ventilator maintenance.

# 7 Maintenance and trouble shooting

## 7.1 Recommended maintenance and quality assurance

Industrial pyranometers can measure reliably at a low level of maintenance in most locations. Unreliable measurements are usually detected as unreasonably large or small measured values. As a general rule, this means that regular visual inspection combined with a critical review of the measured data, preferably checking against other measurements, is the preferred way to attain a reliable measurement.

The IEC 61724-1 standard covering PV system performance monitoring and the WMO manual covering meteorological network operation, have stricter requirements than those in the below table. IEC recommends weekly cleaning and inspection for its Class A systems, and yearly pyranometer re-calibration. WMO recommends daily inspection and cleaning of pyranometers used in meteorological networks.

**Table 7.1.1** Recommended maintenance of industrial pyranometers. If possible, the data analysis and cleaning (1 and 2) should be done on a daily basis (continued on next page).

<b>Minimum recommended pyranometer maintenance</b>			
<b>Interval</b>	<b>Subject</b>	<b>Action</b>	
1	1 week	data analysis	<p>Compare measured data to maximum possible/ maximum expected irradiance and to other measurements nearby (redundant instruments). Also, historical seasonal records can be used as a source for expected values. Analyze nighttime signals. These signals may be negative (down to <math>-5 \text{ W/m}^2</math> on clear windless nights), due to zero offset a. In case of use with PV systems, compare daytime measurements to PV system output. Look for any patterns and events that deviate from what is normal or expected. Check the alerts. If any indicator flags are set, then collect the underlying sensor data of the past year for analysis. Check tilt, internal relative humidity, internal pressure, ventilator speed and heater current according to the recommendations in the chapter about remote diagnostics.</p>
2	2 weeks	cleaning	<p>Use a soft cloth to clean the dome of the instrument, persistent stains can be treated with soapy water or alcohol.</p>
3	3 months	leak-detection	<p>SR300-D1 only: update the reference value for the leak detection, for example using the average leak detection value for the past 24 h.</p>
4	6 months	inspection	<p>Inspect the instrument for any damage. Inspect if the connector is properly attached. Inspect cable quality and connection to the instrument:</p> <ul style="list-style-type: none"> <li>– Verify earthing using a multi-meter.</li> <li>– Inspect connection of the shield.</li> <li>– Inspect connection of RS-485 signal ground to the RS-485 interface.</li> <li>– Inspect connection of instrument power supply.</li> <li>– Check the condition of the connectors (on the chassis as well as the cable).</li> </ul> <p>If instrument is required to be isolated from mounting platform verify isolation. Inspect the dome. Check the dome for scratches or damage, see also the appendix on optical surface imperfections. Inspect the interior of the dome for condensation. Inspect mounting position, inspect leveling and tilt angle and adjust if necessary.</p>

5	2 years	recalibration	<p>Recalibration according to ISO 9847 type A1. For sensitivity adjustment and writing the calibration history data via a PC using the Hukx Sensor Manager software, consult the Hukx Sensor Manager manual for instructions.</p> <p>Typically during calibration desiccant is replaced. Ask the manufacturer for directions.</p> <p>After calibration check that changes in sensitivity do not exceed instrument specifications of non-stability. Stability should be better than 0.5 % change per 5 years. At a calibration uncertainty of approximately 1% this means that in the first 3 years, changes in sensitivity of more than 2 % relative to the original sensitivity should be seen as exceptional.</p>
6	5 years	parts replacement	<p>Desiccant replacement (&lt; 5 year interval, preventive replacement during calibration is advised, two bags of silica gel, 2 x 1 g).</p> <p>SR300-D1 only: ventilator replacement (&lt; 5 year interval).</p> <p>If applicable/necessary, contact our service department to arrange specific parts replacement.</p>

## 7.2 Trouble shooting

Table 7.2.1 Trouble shooting for industrial pyranometers (continued on next pages).

internal high humidity indicator flag set	<p>If the internal high humidity indicator flag is set or the leak detection indicator flag is set, the instrument may have a leak, or the desiccant may be saturated. Look at the long-term (at least a year) trends of pressure, temperature and relative humidity. Contact the manufacturer and send the supporting data file over to discuss servicing options.</p>
leak detection indicator flag set	<p>Whenever the leak detection indicator flag is set, the instrument may have a leak. To investigate leakage, verify that the historic pressure-to-temperature ratio is constant over a period of at least a week. If the instrument is airtight, this ratio should be constant. If the instrument has a leak, the ratio may vary. If a leak is suspected, contact the manufacturer and send the supporting datafile over to discuss servicing options.</p>

Not able to communicate with the instrument

Check all physical connections to the instrument.

Check the cable for broken/damaged wires by measuring the electrical resistance from pins to cable ends. The electrical resistance of every conductor should be  $< 10 \Omega$ . In case of doubt, try a new cable.

Verify the fail-safe biasing networks and bus termination as described in the sections about electrical installation design and the RS-485 network.

Verify that all Modbus server devices on the bus have a unique device address.

Verify that all devices on the bus are using the same serial communication settings. Verify that the Modbus client application is addressing the Modbus server device using the correct device address. Default settings upon delivery are listed in the section on electrical specifications. If settings are not known use the Hukx Sensor Manager. Connect instrument to a PC and perform a search operation with the Sensor Manager to determine the pyranometer's device address and serial communication settings. For SR300-D1 check the status LED, see the section about on-site diagnostics. If all physical connections are correct, and communication with the instrument still cannot be established, contact the manufacturer to discuss servicing options.

The irradiance signal is unrealistically high or low

Note that nighttime signals may be negative (down to  $-5 \text{ W/m}^2$  on clear windless nights in standard operating mode), due to zero offset  $a$  (as defined by ISO 9060). note that heavy rain showers may also result in short-term errors in irradiance values (excluded from zero offsets in ISO 9060).

Verify that the instrument dome is clean.

Check the location of the pyranometer. Check the location for obstructions that could explain the measurement result, see the section about site selection.

Verify that the dome protector has been removed, see the section installation and removal of the dome protector.

Check the orientation/leveling of the pyranometer.

Check if the irradiance signal responds to light: expose the sensor to a strong light source, for instance a 100 W light bulb at 0.1 m distance. The signal should read  $> 100 \text{ W/m}^2$  now. Darken the sensor either by putting something over it or switching off the light. The instrument voltage output should go down and within one minute approach  $0 \text{ W/m}^2$ .

Verify that the irradiance sensitivity programmed into the instrument corresponds to the sensitivity on the calibration certificate.

If not, then update the irradiance sensitivity to the correct value, see the section on adjusting irradiance sensitivity.

Check that the correct Modbus registers are being read. Consult the "[Programming manual industrial pyranometers and diffusometers](#)".

Verify that the two irradiance registers (value is composed of the content of 2 registers) are being read in a single Modbus request.

Check the data acquisition by replacing the instrument with a spare instrument with the same Modbus device address.

The instrument signal shows unexpected variations

Check the presence of strong sources of electromagnetic radiation (radar, radio).

Inspect the measurement location for potential sources of signal variation.

Inspect instrument power supply.

Check the condition and connection of the shield.

Check the condition of the instrument cable.

Check if the cable is not moving during the measurement.

Check the condition of the connectors (on the chassis as well as the cable).

The outer or inner dome shows internal condensation

Contact the manufacturer to discuss servicing options.

Options are as follows:

In case there is a minor layer of moisture that is hardly visible, you may consider to replace the desiccant and wait a few days to see if the situation improves.

Ask the manufacturer for detailed instructions.

In case of condensation of droplets in the instruments:

the instrument sensor and electronics may have been affected. Both can no longer be considered reliable. The factory can perform diagnostics and make a quotation for repair. It may be possible to disassemble the instrument, replace parts and test and calibrate the repaired instrument.

## 7.3 Calibration and validation

### 7.3.1 Indoor calibration in a laboratory

Hukx's recommendation for re-calibration is to perform calibration indoor by comparison to an identical reference instrument, under normal incidence conditions. For more information why indoor and not outdoor calibration is preferred, see the following paragraph on outdoor testing and also our application note "[why indoor calibration is preferable](#)".

Hukx has invested in a worldwide calibration organization, which helps to reduce calibration costs by simplifying return logistics and turnaround times. For more information, see our separate brochure about "[pyranometer calibration services](#)".

The recommended calibration interval of pyranometers is 2 years. The registers containing the applied sensitivity and the calibration history of Hukx industrial pyranometers are accessible for users. This allows the user to choose his own local calibration service.

Calibration is done with a reference pyranometer in a controlled indoor environment. The applicable standard is ISO 9847 "*International Standard: Solar Energy—calibration of field pyranometers by comparison to a reference pyranometer*". At Hukx, an indoor calibration according to the same standard is used.

#### NOTICE

SR300-D1 indoor calibration is possible against a working standard of the SR30 pyranometer models.

#### NOTICE

The calibration reference condition is "medium power mode", i.e. ventilated and not heated.

#### NOTICE

The height of SR300-D1 is different from that of SR30 models. Adjustments should be made to put the black sensor surface at the same height relative to the lamp source.

### 7.3.2 Outdoor validation and calibration using a reference pyranometer

Validation and calibration of pyranometers in field can be done by comparison to a reference pyranometer.

#### NOTICE

Validation and calibration of pyranometers in the field typically is insufficiently accurate for the instrument to be used in PV system performance monitoring.

Validation and calibration of pyranometers in the field has a variable (and not constant) uncertainty that depends on local environmental conditions at the time of calibration. The uncertainty generally will not meet the requirements (better than 2 % expanded measurement uncertainty) of IEC 61724-1 for Class A PV system performance measurement systems.

In case of field comparison, ISO 9847 recommends field validation and calibration relative to a higher class pyranometer. Hukx recommends to use sensors of the same model and class or better, because similar instruments will have comparable offsets. It is therefore just as good to compare to pyranometers of the same brand and type as to compare to an instrument of a higher class.

ISO 9847 recommends to perform field validation and calibration on cloudless and partly clouded days

- during several days, 2 as a minimum
- with individual selection of datasets per calibration
- with data rejection procedure per record, 240 records for cloudless days
- with individual uncertainty evaluation for every calibration, taking the standard deviation of the records into account

In order to shorten the calibration process, Hukx recommends calibration at normal incidence, using hourly totals near solar noon.

Hukx's main recommendations for field intercomparisons are:

1. To take normal incidence as a reference and not the entire day.
2. To take a reference of the same brand and type as the field pyranometer or a pyranometer of a higher class.
3. To connect both to the same electronics, so that electronics errors (also offsets) are eliminated.
4. To mount all instruments on the same platform, so that they have the same body temperature.
5. To analyze radiation values at normal incidence radiation (possibly tilting the radiometers to approximately normal incidence), if this is not possible, to compare 1 hour totals around solar noon for horizontally mounted instruments. Use data of  $> 500 \text{ W/m}^2$  only. If possible use data of  $> 700 \text{ W/m}^2$  only.
6. For spectrally flat Class C radiometers, to correct deviations of more than  $\pm 10 \%$ . Lower deviations should be interpreted as acceptable and should not lead to a revised sensitivity.
7. for spectrally flat Class B pyranometers, to correct deviations of more than  $\pm 5 \%$ . Lower deviations should be interpreted as acceptable and should not lead to a revised sensitivity
8. for spectrally flat Class A instruments, to correct deviations of more than  $\pm 3 \%$ . Lower deviations should be interpreted as acceptable and should not lead to a revised sensitivity

## 7.4 Spare parts

- adjustable leveling feet (set of 2)
- static leveling foot
- sun screen
- 3, 5, 10 or 20 m cable for SR300-D1, with female M12-A connector at instrument end, conductors stripped over 0.15 m with ferrules
- leveling mount, for spring-loaded leveling and mounting on a surface (order number LM01)
- tube leveling mount, for spring-loaded leveling and mounting on a tube, includes LM01 (order number TLM01)
- lower clamp for tube mount
- pair of M5x30 bolts for tube mount
- pair of M5x45 bolts for tube mount
- set of 5 dome protectors
- uninsulated ring terminal with earthing screw
- bag of silica gel, 1 g

## 7.5 Repair services SR300-D1, SR200-D1 and SR100-D1

The outer dome, bubble level, thermopile sensor and internal sensors of SR300-D1, SR200-D1 and SR100-D1 cannot be supplied as spare parts. In case of damage to the pyranometer, after repair the instrument must be tested to verify performance within specification limits. This is required by ISO 9060.

Validation is a test to verify that the instrument is fit for purpose. No certificates or test reports are issued.

Calibration includes a validation, and a certificate is issued. Certificates are also added for directional response -, temperature response - and accelerometer testing.

Table 7.5.1 Required testing of SR300-D1 as a function of the most common repair services.

<b>Servicing SR300-D1</b>				
	<b>dome replacement</b>	<b>PCB replacement</b>	<b>sensor replacement</b>	<b>O-ring/connect or/bubble level replacement</b>
validation (no report issued)	-	-	-	•
calibration (including validation)	•	•	•	-
directional response test	•	•	•	-
temperature response test	•	•	•	-
accelerometer calibration	-	•	-	-

Table 7.5.2 Required testing of SR200-D1 as a function of the most common repair services.

<b>Servicing SR200-D1</b>				
	<b>dome replacement</b>	<b>PCB replacement</b>	<b>sensor replacement</b>	<b>O-ring/connect or/bubble level replacement</b>
validation (no report issued)	-	-	-	•
calibration (including validation)	•	•	•	-
directional response test	•	•	•	-
temperature response test	•	•	•	-

Table 7.5.3 Required testing of SR100-D1 as a function of the most common repair services.

Servicing SR100-D1				
	dome replacement	PCB replacement	sensor replacement	o-ring/connect or/bubble level replacement
validation (no report issued)	-	-	-	•
calibration (including validation)	•	•	•	-

## 7.6 The SR300-D1 ventilator

The nominal ventilator speed is 6000 to 9000 RPM at 20 °C. Speed may vary, depending on operation conditions, especially temperature. The normal startup time is less than 10 seconds. At temperatures below -10 °C the startup time may increase to several minutes and the ventilator speed may drop. The slow startup does not affect the lifetime of the ventilator. Variations of the fan speed do not affect the instrument performance. Replace the ventilator when the speed consistently falls below

2000 RPM. The ventilator life expectancy  $L_{10\%}$  is 70,000 hours and the MTBF (Mean Time Between Failure) is 350,000 hours when continuously operated at 40 °C. Therefore a lifetime < 5 years is specified for the ventilator under typical operating conditions.

The recommended operation is either continuously [ON] or continuously [OFF]. Switching [ON] and [OFF] frequently (for example daily) reduces the ventilator lifetime.

Factors that may negatively impact the fan's lifetime are:

- long operation at elevated temperatures, especially above +70 °C
- frequently (re-)starting the ventilator
- excessive mechanical shocks and vibrations

## 7.7 Scratches on domes—optical surface imperfections

Hukx has in-house test procedures to verify if surface imperfections (scratches and digs) on the pyranometer domes are permissible or not. The procedures essentially check if, with a certain scratch the pyranometer perform as required.

In in-house testing, the requirements, procedures and specifications are according to ISO 10110 "Optics and photonics: Preparation of drawings for optical elements and systems".

ISO 10110-7 "specifies the indication of the level of acceptability of surface imperfections within a test region on individual optical elements and optical assemblies. These include localized surface imperfections, edge chips and long scratches".

We assume that the main risk is damage to the outer surface of the outer dome. Only this surface is checked. We assume other surfaces do not need to be inspected.

## 7.7.1 Inspection of new instruments

For new instruments: consult the ISO 10110 standard. Contact the manufacturer in case surface imperfections on the outer surface of the outer dome exceed ISO 10110: 5/4 x 0.063, while ignoring 0.04 and smaller.

## 7.7.2 Inspection of used instruments

For used instruments, there may in the course of time be additional imperfections. The questions then are:

- Did the sensitivity significantly change?
- Did the directional response significantly change?

The following is a brief and very simplified procedure that can be followed by a user:

1. Mark the scratches on the outer surface of the outer dome. Not those on the inner surface of the outer dome.
2. Make a photograph of the imperfection and next to it a 1 mm scale for comparison, preferably in a dark environment with a single-point light source illuminating the imperfection. Enlarge the picture and make an "on-screen" estimate of the size. Ideally a test should be done using a DIN ISO 10110-7 tool.
3. Estimate the approximate length  $L$  in [mm] and width  $W$  in [mm] of the scratch. Multiply  $L \times W$ . You may also send such pictures to the supplier to get a second opinion.
4. Grade each of the scratches into one of the following categories:
  - A = [larger than 0.026 mm<sup>2</sup>] or using ISO 10110-7 tool [grade 0.16],
  - B = [between 0.026 mm<sup>2</sup> and 0.01 mm<sup>2</sup>] or using ISO 10110-7 tool [grade 0.10],
  - C = [between 0.01 mm<sup>2</sup> and 0.004 mm<sup>2</sup>] or using ISO 10110-7 tool [grade 0.063],
  - D = [smaller than 0.004 mm<sup>2</sup>].In case of doubt between grades, then choose the smaller grade.
5. Ignore all scratches with categorization D.
6. If dome contains 1 or more scratches of category A then [FAIL]
7. If dome contains 2 or more scratches of category B within a circle of 6 mm diameter then: [FAIL]
8. [PASS] if:
  - dome contains 1 scratch of category B and 2 or less scratches of category C
  - dome contains 2 scratches of category B at more than 6 mm distance apart and no scratches of category C
  - dome contains no scratches of category B and 4 or less scratches of category C
9. Other cases [SEND TO FACTORY]

- In case the procedure results in a [FAIL], then the imperfections are clearly too large—dome needs replacement. Send the instrument back to the factory for repair or consider purchasing a new instrument.
- In case the procedure results in a [PASS], then the imperfections are so small they are permitted—they will not have a negative impact on the sensitivity and directional error. Continue using the instrument.
- All remaining cases—[SEND TO FACTORY]—the decision rules at the factory are complicated and depend on the location of the imperfections on the dome. For low-cost instruments, it may be more economical to purchase a new instrument.

NOTE 1: Class A and Class B instruments are repairable, and outer domes can be replaced. For Class C instruments, repair and replacement of domes is not economically attractive.

NOTE 2: in case a dome is replaced for a Class A instrument, a directional response test must be performed to verify that the instrument meets Class A directional response requirements.

NOTE 3: ISO 10110 tests for surface imperfections are subjective.

# 8 Appendices

## 8.1 Appendix on standards for classification and calibration

Both ISO and ASTM have standards on instrument classification and methods of calibration. The World Meteorological Organization (WMO) has largely adopted the ISO classification system.

Table 8.1.1 Pyranometer standardization in ISO and ASTM.

Standards on instrument classification and calibration	
ISO standard	equivalent ASTM standard
ISO 9060:2018 <i>Solar energy—Specification and classification of instruments for measuring hemispherical solar and direct solar radiation</i>	not available Comment: work is in progress on a new ASTM equivalent standard.
ISO 9846:1993 <i>Solar energy—Calibration of a pyranometer using a pyr heliometer</i>	ASTM G167-15 <i>Standard Test Method for Calibration of a Pyranometer Using a Pyr heliometer</i>
ISO 9847:2023 <i>Solar energy—Calibration of pyranometers by comparison to a reference pyranometer</i>	ASTM E824-10 <i>Standard Test Method for Transfer of Calibration from Reference to Field Radiometers</i>  ASTM G207-11 <i>Standard Test Method for Indoor Transfer of Calibration from Reference to Field Pyranometers</i>
ISO 9059:1990 <i>Solar energy—Calibration of field pyr heliometers by comparison to a reference pyr heliometer</i>	ASTM E816-15 <i>Standard Test Method for Calibration of Pyr heliometers by Comparison to Reference Pyr heliometers</i>

## 8.2 Appendix on calibration hierarchy

Traceability of pyranometer and pyr heliometer sensitivities is to SI via the World Radiometric Reference, WRR. WRR is a “consensus standard”. The distinguishing feature of traceability to WRR is that reference-operating conditions include the spectrum of natural direct solar radiation (source ISO 9847:2023). WRR is maintained by the World Radiation Center in Davos Switzerland (PMOD /WRC), using a group of instruments called the World Standard Group (WSG). PMOD/WRC is a designated institute of the Swiss Federal Office of Metrology, the Swiss signatory of the CIPM Mutual Recognition Agreement (MRA). PMOD/WRC has an MRA with WMO as well.

The use of WRR is mandatory when working according to the standards of both WMO and ISO. ISO 9874 states under Paragraph 1.3: the methods of calibration specified are traceable to the WRR. The WMO manual states under Paragraph 7.1.2.2: the WRR is accepted as representing the physical units of total irradiance.

See [www.pmodwrc.ch](http://www.pmodwrc.ch)

The Hukx standard is traceable to an outdoor WRR calibration. Some small corrections are made to transfer this calibration to the Hukx standard conditions: sun at zenith and 1000 W/m<sup>2</sup> irradiance level. During the outdoor calibration, the sun is typically at 20 to 40 ° zenith angle, and the total irradiance is around a 700 W/m<sup>2</sup> level.

Table 8.2.1 Calibration hierarchy for pyranometers.

## Working standard calibration at PMOD / WRC davos

Calibration of working standard pyranometers:

Method: outdoor calibration using the "continuous sun-and-shade method". This working standard has an uncertainty "uncertainty of standard". The working standard has been calibrated under certain "test conditions of the standard". The working standard has traceability to WRR world radiometric reference.

## Correction of (working) standard calibration to standardized reference conditions

Correction from "test conditions of the standard" to "reference conditions" i.e. to 20 °C, normal incidence, horizontal mounting and an irradiance level of 1000 W/m<sup>2</sup>:

Using known working standard pyranometer properties: temperature response, directional response, non-linearity, tilt response.

## Indoor product calibration

Calibration of products, i.e. pyranometers:

Method: according to ISO 9847, Type A1, which is an indoor calibration.

This calibration has an uncertainty associated with the method.

## Calibration uncertainty evaluation

ISO 98-3 *Guide to the Expression of Uncertainty in Measurement*, GUM

Hukx determined the combined expanded uncertainty of the product's calibration, including uncertainty of the working standard, uncertainty of correction, and uncertainty of the method (transfer error). The resulting uncertainty depends on the pyranometer model. This result and a summary of contributions to the uncertainty budget can be found on the calibration certificate.

### 8.3 Appendix on expected change of the WRR scale

The WRR has been accepted since 1980 as representing the physical units of solar irradiance.

WRR contains a systematic error relative to SI. Therefore, the WRR scale will be changed, likely by 0.34 %.

The WRR scale was too high, which means that all irradiance measured with traceability to WRR must be corrected to lower values in  $[W/m^2]$ .

With the correction from WRR to the new scale, the sensitivities of instruments in  $[V/(W/m^2)]$  will go up by 0.34 %.

WMO does not recommend to correct past data. It does, however, recommend to store information about the scale.

Hukseflux in its latest industrial pyranometers allows to add metadata, to indicate if calibration is traceable to WRR or to the new scale, to calibration records and to records of calibration history. All these records are stored in the instrument.

A reference for the scale change is:

Fehlmann A., Kopp G., Schmutz W. et al. *Fourth World Radiometric Reference to SI radiometric scale comparison and implications for on-orbit measurements of the total solar irradiance*. Metrologica 49 (2012) p34-38.

## 8.4 Appendix on meteorological radiation quantities

A pyranometer measures irradiance. The time integrated total is called radiant exposure. In solar energy, radiant exposure is often given in  $W \cdot h/m^2$ .

Table 8.4.1 Meteorological radiation quantities recommended by WMO (additional symbols by Hukx). POA originates from ASTM and IEC standards.

Symbol	Description	Calculation	Units	Alternative expression	
$E_{\downarrow}$	downward irradiance	$E_{\downarrow} = E_{g\downarrow} + E_{l\downarrow}$	$W/m^2$		
$H_{\downarrow}$	downward radiant exposure for a specified time interval	$H_{\downarrow} = H_{g\downarrow} + H_{l\downarrow}$	$J/m^2$ or $W \cdot h/m^2$		
$E_{\uparrow}$	upward irradiance	$E_{\uparrow} = E_{g\uparrow} + E_{l\uparrow}$	$W/m^2$		
$H_{\uparrow}$	upward radiant exposure for a specified time interval	$H_{\uparrow} = H_{g\uparrow} + H_{l\uparrow}$	$J/m^2$ or $W \cdot h/m^2$		
$E$	direct solar irradiance normal to the apparent solar zenith angle		$W/m^2$	DNI	Direct Normal Irradiance
$E_0$	solar constant		$W/m^2$		
$E_{g\downarrow h}$	global irradiance—hemispherical irradiance on a specified, in this case horizontal surface.*	$E_{g\downarrow} = E \cdot \cos \theta_h + E_{d\downarrow}$	$W/m^2$	GHI	Global Horizontal Irradiance
$E_{g\downarrow t}$	global irradiance—hemispherical irradiance on a specified, in this case tilted surface.*	$E_{g\downarrow} = E \cdot \cos \theta_t + E_{d\downarrow t} + E_{l\uparrow t}$ ***	$W/m^2$	POA	Plane of Array irradiance
$E_{d\downarrow}$	downward diffuse solar radiation		$W/m^2$	DHI	Diffuse Horizontal Irradiance
$E_{l\uparrow}, E_{l\downarrow}$	upward/downward longwave irradiance		$W/m^2$		
$E_r$	reflected solar irradiance		$W/m^2$		
$E^*$	net irradiance	$E^* = E_{\downarrow} - E_{\uparrow}$	$W/m^2$		
$T_{\downarrow}$	apparent surface temperature**		$^{\circ}C$ or $K$		
$T_{\uparrow}$	apparent sky temperature***		$^{\circ}C$ or $K$		
SD	sunshine duration		h		

$\theta$  is the apparent solar zenith angle  $\theta_h$  relative to horizontal,  $\theta_t$  relative to a tilted surface  
 $g$  = global,  $l$  = long wave,  $t$  = tilted \*,  $h$  = horizontal\*

\* distinction horizontal and tilted from Hukx,  
\*\* T symbols introduced by Hukx,  
\*\*\* contributions of  $E_{d\downarrow t}$  and  $E_{l\uparrow t}$  are  $E_{d\downarrow}$  and  $E_{l\uparrow}$  both corrected for the tilt angle of the surface

## 8.5 Appendix on ISO 9060:2018 and WMO classification tables

**Table 8.5.1** Valid classification table for pyranometers per ISO 9060:2018 and WMO. NOTE: WMO specification of spectral selectivity is different from that of ISO. Hukx conforms to the ISO limits. WMO also specifies expected accuracies. ISO finds this not to be a part of the classification system, because it also involves calibration. Note that WMO achievable accuracies are for clear days at mid-latitudes and that the uncertainty estimate does not include uncertainty due to calibration\*. Continued on next page.

ISO accuracy class	Class A	Class B	Class C
<b>ISO 9060:2018 classification** table</b>			
<b>specification acceptance interval (guard band)</b>			
response time (95 %)	10 s (1s)	20 s (1s)	60 s (1s)
zero offset a (response to 200 W/m <sup>2</sup> net thermal radiation)	± 7 W/m <sup>2</sup> (2 W/m <sup>2</sup> )	± 15 W/m <sup>2</sup> (2 W/m <sup>2</sup> )	± 30 W/m <sup>2</sup> (3 W/m <sup>2</sup> )
zero offset b (response to 5 K/h in ambient temperature)***	± 2 W/m <sup>2</sup> (0.5 W/m <sup>2</sup> )	± 4 W/m <sup>2</sup> (0.5 W/m <sup>2</sup> )	± 8 W/m <sup>2</sup> (1 W/m <sup>2</sup> )
zero offset c (total zero offset)	± 10 W/m <sup>2</sup> (2 W/m <sup>2</sup> )	± 21 W/m <sup>2</sup> (2 W/m <sup>2</sup> )	± 41 W/m <sup>2</sup> (3 W/m <sup>2</sup> )
non-stability (change per year)	± 0.8 % (0.2 %)	± 1.5 % (0.25 %)	± 3 % (0.5 %)
non-linearity (100 to 1000 W/m <sup>2</sup> )	± 0.5 % (0.2 %)	± 1 % (0.2 %)	± 3 % (0.5 %)
directional response	± 10 W/m <sup>2</sup>	± 20 W/m <sup>2</sup>	± 30 W/m <sup>2</sup>
for spectrally flat subcategory only: spectral selectivity (350 to 1500 x 10 <sup>-9</sup> m)	± 3 % (2 %)	± 3 % (2 %)	± 3 % (2 %)
clear sky global horizontal irradiance spectral error	± 0.5 % (0.1 %)	± 1 % (0.5 %)	± 5 % (1 %)
temperature response (interval -10 to +40 ° C relative to 20 °C)**	± 1 % (0.2 %)	± 2 % (0.2 %)	± 4 % (0.5 %)
tilt response (0 to 180 ° at 1000 W/m <sup>2</sup> )	± 0.5 % (0.2 %)	± 2 % (0.5 %)	± 5 % (0.5 %)
additional signal processing errors	± 2 W/m <sup>2</sup> (2 W/m <sup>2</sup> )	± 5 W/m <sup>2</sup> (2 W/m <sup>2</sup> )	± 10 W/m <sup>2</sup> (2 W/m <sup>2</sup> )
conformity testing**	temperature and directional test for every individual instrument	group compliance	group compliance

for fast response subclass only: response time (95 %)	0.5 s	0.5 s	0.5 s
<b>Additional WMO specifications</b>			
<b>WMO class</b>	<b>high quality</b>	<b>good quality</b>	<b>moderate quality</b>
WMO: achievable accuracy for daily sums*	2 %	5 %	10 %
WMO: achievable accuracy for hourly sums**	3 %	8 %	20 %
WMO: achievable accuracy for minute sums***	not specified	not specified	not specified
WMO: resolution (smallest detectable change)	1 W/m <sup>2</sup>	5 W/m <sup>2</sup>	10 W/m <sup>2</sup>

\* WMO 7.2.1: The estimated uncertainties are based on the following assumptions:  
(a) instruments are well-maintained, correctly aligned and clean  
(b) 1 min and 1 h figures are for clear-sky irradiances at solar noon  
(c) daily exposure values are for clear days at mid-latitudes. WMO 7.3.2.5: Table 7.5 lists the expected maximum deviation from the true value, excluding calibration errors.

\*\* ISO 9060:2018: an instrument is subject to conformity testing of its specifications. The classification of pyranometers may be applied to individual instruments or to groups (particular types) of instruments, depending on the category. A pyranometer type (pyranometers of identical design) may be claimed to be of a particular class even without individual tests depending on the class if the appropriate quality control has shown that pyranometers of this type comply with the respective specifications.

For the classification of a pyranometer in the highest Class A, individual tests of temperature response and directional response are required. A specification is fulfilled if:  
a) The value of the respective test result lies in the corresponding acceptance interval given in Table 1 for the specific class of instrument.  
b) The sum of the absolute amounts of the expanded uncertainty of the test and the test result is less or equal to the absolute amount of the limit of the tolerance interval (guarded acceptance)—the tolerance interval is determined by the acceptance interval and the guard bands from ISO 9060:2018 Table 1 (same as 10.8.1). Reference: JCGM 106 and ISO /IEC Guide 98-4 *Uncertainty of measurement—Part 4: Role of measurement uncertainty in conformity assessment*.

\*\*\* In ISO 9060 offsets due to rapid temperature changes by cold rain showers are excluded from zero offset b.

## 8.6 Appendix on ISO 9060:1990 classification no longer valid

**Table 8.6.1** Former classification table for pyranometers per ISO 9060:1990 and WMO. ISO 9060:1990 has been superseded by ISO 9060:2018, see the earlier appendix on ISO and WMO classification tables.

NOTE: WMO specification of spectral selectivity is different from that of ISO. Hukx conforms to the ISO limits. WMO also specifies expected accuracies. ISO finds this not to be a part of the classification system, because it also involves calibration. Note that WMO achievable accuracies are for clear days at mid-latitudes and that the uncertainty estimate does not include uncertainty due to calibration\*.

### Former ISO 9060:1990 classification table (superseded by ISO 9060:2018)

ISO class	Secondary standard	First class	Second class
specification limit			
response time (95 %)	15 s	30 s	60 s
zero offset a (response to 200 W/m <sup>2</sup> net thermal radiation)	+7 W/m <sup>2</sup>	+15 W/m <sup>2</sup>	+30 W/m <sup>2</sup>
zero offset b (response to 5 K/h in ambient temperature)	±2 W/m <sup>2</sup>	±4 W/m <sup>2</sup>	±8 W/m <sup>2</sup>
non-stability (change per year)	±0.8 %	±1.5 %	±3 %
non-linearity (100 to 1000 W/m <sup>2</sup> )	±0.5 %	±1 %	±3 %
directional response	±10 W/m <sup>2</sup>	±20 W/m <sup>2</sup>	±30 W/m <sup>2</sup>
spectral selectivity (350 to 1500 x 10 <sup>-9</sup> m)	±3 %	±5 %	±10 %
temperature response (interval of 50 K)**	2 %	4 %	8 %
tilt response (0 to 90 ° at 1000 W/m <sup>2</sup> )	±0.5 %	±2 %	±5 %

### Additional WMO specifications

WMO class	high quality	good quality	moderate quality
spectral selectivity (300 to 3 000 x 10 <sup>-9</sup> m)	±2 %	±5 %	±10 %
WMO: achievable accuracy for daily sums*	2 %	5 %	10 %
WMO: achievable accuracy for hourly sums*	3 %	8 %	20 %
WMO: achievable accuracy for minute sums*	not specified	not specified	not specified
WMO: resolution (smallest detectable change)	1 W/m <sup>2</sup>	5 W/m <sup>2</sup>	10 W/m <sup>2</sup>

## Conformity testing<sup>\*\*\*</sup>

ISO 9060

individual  
instrument only:  
all specs must  
comply

group  
compliance

group  
compliance

\* WMO 7.2.1: The estimated uncertainties are based on the following assumptions:  
(a) instruments are well-maintained, correctly aligned and clean  
(b) 1 min and 1 h figures are for clear-sky irradiances at solar noon  
(c) daily exposure values are for clear days at mid-latitudes.  
WMO 7.3.2.5: Table 7.5 lists the expected maximum deviation from the true value, excluding calibration errors.

\*\* At Hukx the expression  $\pm 1\%$  is used instead of "a range of 2 %".

\*\*\* ISO 9060:1990 an instrument is subject to conformity testing of its specifications. Depending on the classification, conformity compliance can be proven either by group or individual compliance. A specification is fulfilled if the mean value of the respective test result does not exceed the corresponding limiting value of the specification for the specific category of instrument.

## 8.7 Appendix on the definition of pyranometer specifications

Table 8.7.1 Definition of pyranometer specifications.

specification	definition	source
response time (95 %)	Time for 95 % response. The time interval between the instant when a stimulus is subjected to a specified abrupt change and the instant when the response reaches and remains within specified limits around its final steady value. The response time is a measure of the thermal inertia inherent in the stabilization period for a final reading.	ISO 9060:2018 WMO 1.6.3
zero offset a (200 W/m <sup>2</sup> net thermal radiation)	Response to 200 W/m <sup>2</sup> net thermal radiation (ventilated). Hukx assumes that unventilated instruments have to specify the zero-offset in unventilated—worst case—conditions. Zero offsets are a measure of the stability of the zero-point. Zero offset a is visible at night as a negative offset, the instrument dome irradiates in the far infrared to the relatively cold sky. This causes the dome to cool down. the pyranometer sensor irradiates to the relatively cool dome, causing a negative offset. Zero offset a is also assumed to be present during daytime.	ISO 9060:2018
zero offset b (5 K/h in ambient temperature)	Response to 5 K/h change in ambient temperature. zero offsets are a measure of the stability of the zero-point. Offsets due to rapid temperature changes by cold rain showers are excluded from zero offset b.	ISO 9060:2018
zero offset c	Total zero offset including the effects of zero offset a and b and other sources.	ISO 9060:2018
non-stability (change per year)	Percentage change in sensitivity per year. The dependence of sensitivity resulting from ageing effects which is a measure of the long-term stability.	ISO 9060:2018
non-linearity (100 to 1000 W/m <sup>2</sup> )	Percentage deviation from the sensitivity at 500 W/m <sup>2</sup> due to the change in irradiance within the range of 100 W/m <sup>2</sup> to 1000 W/m <sup>2</sup> . Non-linearity has an overlap with directional response, and therefore should be handled with care in uncertainty evaluation.	ISO 9060:2018
directional response	The range of errors caused by assuming that the normal incidence sensitivity is valid for all directions when measuring from any direction (with an incidence angle of up to 90 ° or even from below the sensor) a beam radiation whose normal incidence irradiance is 1000 W/m <sup>2</sup> . Directional response is a measure of the deviations from the ideal "cosine behavior" and its azimuthal variation. Appendix A5: measurement should be made at least at the following directions: incidence angles of 40 °, 60 °, 70 °, 80 ° and 95 ° at four azimuth angles (e.g. 0 °, 90 °, 180 °, 270 °).	ISO 9060:2018

spectral selectivity (350 to 1500 x 10 <sup>-9</sup> m) (WMO 300 to 3000 x 10 <sup>-9</sup> m)	Percentage deviation of the product of spectral absorptance and spectral transmittance from the corresponding mean within 350 x 10 <sup>-9</sup> m to 1500 x 10 <sup>-9</sup> m and the spectral distribution of irradiance. Spectral selectivity is a measure of the spectral selectivity of the sensitivity.	ISO 9060:2018
clear sky global horizontal irradiance spectral error	Maximum spectral error observed for a set of global horizontal irradiance clear sky spectra defined in this document ISO 9060:2018.	ISO 9060:2018
temperature response (interval of 50 K)	Percentage deviation of the sensitivity due to change in ambient temperature within the interval of -10 °C to +40 °C relative to 20 °C.	ISO 9060:2018
tilt response (0° to 180° at 1000 W/m <sup>2</sup> )	Percentage deviation from the sensitivity at 0° tilt (horizontal) due to a change in tilt from 0 ° to 180 ° at 1000 W/m <sup>2</sup> irradiance. Tilt response describes changes in the sensitivity due to changes of the tilt angle of the receiving surface.	ISO 9060:2018
additional signal processing errors	The additional signal processing errors contain data acquisition and analog to digital conversion that might be carried out in the instrument and all other processing steps carried out within the instrument that are not covered by the other specifications.	ISO 9060:2018
sensitivity	The change in the response of a measuring instrument divided by the corresponding change in the stimulus.	WMO 1.6.3
spectral range	The spectral range of radiation to which the instrument is sensitive. For a normal pyranometer this should be in the (0.3 to 3) x 10 <sup>-6</sup> m range. Some pyranometers with colored glass domes have a limited spectral range.	Hukx

## 8.8 Appendix on terminology/glossary

Table 8.8.1 Definitions and references of used terms.

term	definition (reference)
solar energy or solar radiation	Solar energy is the electromagnetic energy emitted by the sun. Solar energy is also called solar radiation and shortwave radiation. The solar radiation incident on the top of the terrestrial atmosphere is called extra-terrestrial solar radiation—97 % of which is confined to the spectral range of $(290 \text{ to } 3\,000) \times 10^{-9} \text{ m}$ . Part of the extra-terrestrial solar radiation penetrates the atmosphere and directly reaches the earth's surface, while part of it is scattered and/or absorbed by the gas molecules, aerosol particles, cloud droplets and cloud crystals in the atmosphere. The former is the direct component, the latter is the diffuse component of the solar radiation. (ref: WMO, Hukx).
hemispherical solar radiation	Solar radiation received by a plane surface from a $180^\circ$ field of view angle (solid angle of $2\pi \text{ sr}$ ). (ref: ISO 9060)
global solar radiation	Also GHI: the solar radiation received from a $180^\circ$ field of view angle on a horizontal surface is referred to as global radiation. Also called GHI. This includes radiation received directly from the solid angle of the sun's disc, as well as diffuse sky radiation that has been scattered in traversing the atmosphere (ref: WMO). Hemispherical solar radiation received by a horizontal plane surface (ref: ISO 9060).
direct solar radiation	Radiation received from a small solid angle centered on the sun's disc, on a given plane (ref: ISO 9060).
Direct Normal Irradiance	Also DNI: radiation received from a small solid angle centered on the sun's disc, on a plane normal to its direction (ref: ISO 9060).
diffuse solar radiation	Hemispherical radiation minus coplanar direct radiation (ref: ISO 9060).
Diffuse Horizontal Irradiance	Also DHI: global horizontal irradiance minus coplanar direct radiation (the portion emanating from the solar disk and from the circumsolar region of the sky within a subtended full angle of $5^\circ$ ) (ref: IEC 61724-1).
Plane of Array irradiance	Also POA: hemispherical solar irradiance in the plane of a PV array. sum of direct, diffuse, and ground-reflected irradiance incident upon the frontside of an inclined surface parallel to the plane of the modules in the PV array (ref: ASTM E2848-11 / IEC 61724).
reflected irradiance	Ground-reflected irradiance incident upon a defined surface, typically parallel to the plane of the modules in the (bifacial) PV array.

Rearside Plane of Array irradiance	Also POA <sup>rear</sup> : sum of direct, diffuse, and ground-reflected irradiance incident on the back side of an inclined surface parallel to the plane of the modules in the PV array (ref: IEC 61724, ISO TR 9901).
Reflected Horizontal Irradiance	Also RHI: ground-reflected irradiance incident upon a surface, oriented horizontally facing down (ref: IEC 61724, ISO TR 9901).
terrestrial or longwave radiation	Radiation not of solar origin, but of terrestrial and atmospheric origin and having longer wavelengths (3 000 to 100 000) x 10 <sup>-9</sup> m). In case of downwelling E <sub>i</sub> ↓ also the background radiation from the universe is involved, passing through the "atmospheric window". In case of upwelling E <sub>i</sub> ↑, composed of longwave electromagnetic energy emitted by the earth's surface and by the gases, aerosols and clouds of the atmosphere—it is also partly absorbed within the atmosphere. For a temperature of 300 K, 99.99 % of the power of the terrestrial radiation has a wavelength longer than 3 000 x 10 <sup>-9</sup> m and about 99 per cent longer than 5 000 x 10 <sup>-9</sup> m. For lower temperatures, the spectrum shifts to longer wavelengths (ref: WMO).
World Radiometric Reference (WRR)	Measurement standard representing the SI unit of irradiance with an uncertainty of less than ±0.3 % (see the WMO Guide to Meteorological Instruments and Methods of Observation, 1983, subclause 9.1.3). The reference was adopted by the World Meteorological Organization (WMO) and has been in effect since 1 July 1980 (ref: ISO 9060).
albedo	Ratio of reflected and incoming solar radiation. Dimensionless number that varies between 0 and 1. Typical albedo values are: < 0.1 for water, from 0.1 for wet soils to 0.5 for dry sand, from 0.1 to 0.4 for vegetation, up to 0.9 for fresh snow.
angle of incidence	Angle of radiation relative to the sensor measured from normal incidence (varies from 0 ° to 90 °).
zenith angle	Angle of incidence of radiation, relative to zenith. Equals angle of incidence for horizontally mounted instruments.
azimuth angle	Angle of incidence of radiation, projected in the plane of the sensor surface. Varies from 0 ° to 360 °. 0 is by definition the cable exit direction, also called north, east is +90 ° (ASTM G113-09).
sunshine duration	Sunshine duration during a given period is defined as the sum of that sub-period for which the direct solar irradiance exceeds 120 W/m <sup>2</sup> (ref: WMO).

## 8.9 Appendix on uncertainty evaluation

The uncertainty of a measurement under outdoor or indoor conditions depends on many factors, see Paragraph 1 of this chapter. It is not possible to give one figure for pyranometer measurement uncertainty. The work on uncertainty evaluation is a continuous effort. There are several groups around the world participating in standardization of the method of calculation. The consensus is that measurement uncertainty should be evaluated according to the *“Guide to Expression of Uncertainty in Measurement”* or GUM.

### 8.9.1 Evaluation of measurement uncertainty under outdoor conditions

Hukx actively participates in the discussions about pyranometer measurement uncertainty—we also provide spreadsheets, reflecting the latest state of the art, to assist our users in making their own evaluation. The input to the assessment is summarized:

1. The formal evaluation of uncertainty should be performed in accordance with ISO 98-3 *Guide to the Expression of Uncertainty in Measurement*, GUM.
2. The specifications of the instrument, acceptance interval plus guard band, according to the list of ISO 9060 classification of pyranometers and pyrhemometers are entered as limiting values of possible errors, to be analyzed as type B evaluation of standard uncertainty per Paragraph 4.3.7. of GUM. A priori distributions are chosen as rectangular.
3. A separate estimate has to be entered to allow for estimated uncertainty due to the instrument maintenance level.
4. The calibration uncertainty has to be entered. Note that Hukx calibration uncertainties are lower than those of alternative equipment. These uncertainties are entered in measurement equation (equation is usually Formula 0.1:  $E = U/S$ ), either as an uncertainty in E (zero offsets, directional response) in U (voltage read-out errors) or in S (tilt error, temperature dependence, calibration uncertainty).
5. In uncertainty analysis for pyranometers, the location and date of interest is entered. The course of the sun is then calculated, and the direct and diffuse components are estimated, based on a model—the angle of incidence of direct radiation is a major factor in the uncertainty.
6. In uncertainty analysis for modern pyrhemometers: tilt angle dependence often is so low that one single typical observation may be sufficient.
7. In case of special measurement conditions, typical specification values are chosen. These should for instance account for the measurement conditions (shaded/unshaded, ventilated/unventilated, horizontal/tilted) and environmental conditions (clear sky/cloudy, working temperature range).
8. Among the various sources of uncertainty, some are “correlated”; i.e. present during the entire measurement process, and not cancelling or converging to zero when averaged over time—the off-diagonal elements of the covariance matrix are not zero. Paragraph 5.2 of GUM.
9. Among the various sources of uncertainty, some are “uncorrelated”; cancelling or converging to zero when averaged over time—the off-diagonal elements of the covariance matrix are zero. Paragraph 5.1 of GUM.
10. Among the various sources of uncertainty, some are “not included in analysis”—this applies for instance to non-linearity for pyranometers, because it is already included in the directional error, and to the tilt response for pyranometers when measuring global horizontal irradiance.

## 8.9.2 Estimates of achievable uncertainties

There is no general consensus on uncertainty evaluation of pyranometer measurements. Hence uncertainty estimates may vary depending on the method. Table 8.9.2.1 list achievable uncertainties following the “*WMO Guide to Instruments and Methods of Observation: Volume I—Measurement of Meteorological Variables, 2023 edition*” as well as the achievable uncertainties obtained by following the “*ASTM G213 Standard Guide for Evaluating Uncertainty in Calibration and Field Measurements of Broadband Irradiance with Pyranometers and Pyrhemimeters.*”

Table 8.9.2.1 Estimates of achievable uncertainties according to WMO Guide and ASTM G213-17.

Overview of achievable uncertainties (various sources)			
	SR300-D1	SR200-D1	SR100-D1
WMO estimate on achievable accuracy for daily totals*	2 %	2 %	5 %
WMO estimate on achievable accuracy for hourly totals**	3 %	3 %	8 %
Manufacturer’s estimate of achievable accuracy for daily totals in summer at mid latitudes, following ASTM G213 uncertainty evaluation	2.3 %	2.4 %	4.6 %

\* WMO states that this uncertainty may be achieved with appropriate facilities, well-trained staff and good quality control for clear days at mid-latitudes.

\*\* WMO states that this uncertainty may be achieved with appropriate facilities, well-trained staff and good quality control for clear days at mid-latitudes, at solar noon.

The table below provides estimates of achievable uncertainties for various seasons and locations.

**Table 8.9.2.2** Estimates of achievable uncertainties of measurements with pyranometers. The estimates are based on the pyranometer specifications and ISO 9060:2018 specification limits, (tolerance intervals including guard bands), and typical calibration uncertainties, for sunny, clear sky days and well-maintained stations, without uncertainty loss due to lack of maintenance and due to instrument fouling. The table specifies expanded uncertainties with a coverage factor of 2 and a confidence level of 95 %. Estimates are based on 1 s sampling. **IMPORTANT NOTE:** there is no international consensus on uncertainty evaluation of pyranometer measurements, so this table should not be used as a formal reference.

<b>pyranometer class (ISO 9060)</b>	<b>season</b>	<b>latitude</b>	<b>uncertainty minute totals at solar noon</b>	<b>uncertainty hourly totals at solar noon</b>	<b>uncertainty daily totals</b>	
spectrally flat Class A (SR300-D1)	summer	mid-latitude	1.8 %	1.8 %	2.3 %	
		equator	1.8 %	1.8 %	2.3 %	
		pole	2.5 %	2.5 %	3.3 %	
	winter	mid-latitude	3.5 %	3.5 %	5.1 %	
	spectrally flat Class A (SR200-D1)	summer	mid-latitude	1.8 %	1.8 %	2.4 %
			equator	1.8 %	1.8 %	2.3 %
pole			2.5 %	2.5 %	3.3 %	
winter		mid-latitude	3.6 %	3.6 %	5.3 %	
spectrally flat Class B (SR100-D1)		summer	mid-latitude	3.7 %	3.7 %	4.6 %
			equator	3.7 %	3.7 %	4.6 %
	pole		5.0 %	5.0 %	6.5 %	
	winter	mid-latitude	6.9 %	7.0 %	9.9 %	
	spectrally flat Class C	summer	mid-latitude	11.7 %	11.8 %	14.1 %
			equator	11.8 %	11.8 %	13.7 %
pole			13.8 %	13.8 %	16.7 %	
winter		mid-latitude	17.4 %	17.6 %	25.1 %	

## 8.10 Appendix on accelerometer measurements

This appendix provides specific details for configuring the tilt alerts and provides mathematical relations between measurands.

When mounting the instrument with a fixed orientation, the x-, y-, and z-components, tilt and rotation, or tilt x and tilt y measurements can be used to monitor slow, long-term changes as well as incidents that cause the instrument to move. This can be done either by directly reading the registers or, for the tilt and rotation or tilt x and tilt y, by monitoring their respective indicator flags, which act as alerts for change of tilt and rotation or tilt x and tilt y.

To use the tilt and rotation indicator flags, the tilt and rotation reference values and an acceptable range of deviation from the reference must be set. Likewise, to use the tilt x and tilt y indicator flags, set the corresponding reference values and an acceptable range of deviation from the reference. To set up the tilt and rotation alerts after installation, read out the tilt and rotation registers and subsequently write to the tilt and rotation reference registers. Similarly, to set up the tilt x and tilt y alerts, read out the tilt x and tilt y registers and subsequently write to the tilt x and tilt y reference registers. This may be done using the Hukx Sensor Manager or with any other tool or system supporting the Modbus RTU protocol. Consult the ["Programming manual industrial pyranometers and diffusometers"](#) and the register list of the specific instrument for further instructions and information about available registers for different instruments. Whenever the difference between the current value and the reference value exceeds the reference range, the corresponding indicator register flag will be set. Whenever the tilt, rotation, tilt x, or tilt y indicator flag gets set, it is recommended to verify that the instrument is properly fixed to its mounting platform and to realign the instrument beforehand if necessary. The flags reset automatically when the fault condition is no longer present.

As explained in section 6.3.3, there are three mathematically equivalent descriptions to fully determine the orientation of the pyranometer with respect to the gravitational field:

- accelerometer x-, y-, and z-components
- tilt and rotation
- tilt x and tilt y

See the table below for the mathematical relationships between these measurands. In these equations, x, y, and z are accelerometer components and arctan2 is the two-argument arctangent.

### Mathematical relationships between accelerometer measurands

measurand	equation
instrument tilt	$\text{arctan2}(\sqrt{x^2 + y^2}, z)$
instrument rotation	$\text{arctan2}(y, x)$
instrument tilt x*	$\text{arctan2}(-y, z)$
instrument tilt y*	$\text{arctan2}(x, z)$

\* for firmware version 1.9.0 and above

## 8.11 Appendix on the Hukx and Hukseflux brand names

For many years, we have traded our products under the Hukseflux brand name. In 2026, the Hukseflux brand name was changed to Hukx.

Hukseflux Thermal Sensors B.V. herewith confirms that:

- Hukx is a trade name which falls under the same legal entity that was valid for Hukseflux products, "Hukseflux Thermal Sensors B.V."
- specifications of Hukx products are equal to or better than those of Hukseflux products of the same model.

## 8.12 EU declaration of conformity

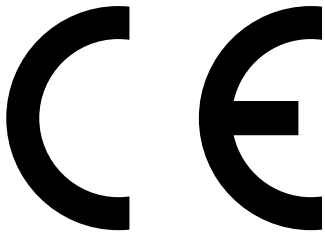

We, Hukseflux Thermal Sensors B.V.,  
Delftechpark 31, 2628 XI, Delft,  
The Netherlands

hereby declare under our sole responsibility that:

Product models	SR300-D1, SR200-D1, SR100-D1
Product type	Pyranometer
Brand name	Hukx

conform with the following directive(s):

2011/65/EU, EU 2015/863	The Restriction of Hazardous Substances Directive
2014/30/EU	The Electromagnetic Compatibility Directive
2006/42/EC	The Machinery Directive

This conformity is declared using the relevant sections and requirements of the following standards,

Hazardous substances	EU RoHS2 (2011/65/EU) and EU 2015/863 amendment known as RoHS3
EMC Emission	EN-IEC 61326-1:2013, EN-IEC 61326-1:2021 (report 230473RPT02)
EMC Immunity	EN-IEC 61326-1:2013, EN-IEC 61326-1:2021, EN-IEC 61000-6-2:2019 (report 230473RPT02)

A handwritten signature in blue ink, appearing to be 'Eric Hoeksema', written over a light blue grid background.

Eric HOEKSEMA  
Director  
Delft, 22 May 2024

## About Hukx

Hukx is the leading innovator in solar radiation and heat flux sensor technology. We are proud to set the standard in high-accuracy measurement, and to be working at the heart of the energy transition.

Customers worldwide rely on our bestselling pyranometers and heat flux sensors. From sensor design and selection to supply and recalibration, we support you across the entire lifecycle.

Hukx is headquartered in the Netherlands, with locally owned representative sales offices in the USA, Brazil, India, China, Southeast Asia, and Japan.

Let us help you select the best sensor for your application. Get in touch with our experts today via: [info@hukx.com](mailto:info@hukx.com)

© Hukx

Version 2630

We reserve the right to change specifications without prior notice.

[www.hukx.com](http://www.hukx.com)

**HUKX**